

Organic Electrochemistry

Untapped Potential for Synthetic Chemists?

Helena Pickford

Literature Review | 17.01.20

Prof. Ed Anderson
Group



Review Outline

Introduction

- Organic Electrochemistry
- Key Milestones
- Underlying theory

Practicalities & Applications

- Experimental Parameters
- Electrolysis Methods
- Applications
 - Industrial Processes
 - Natural Product Synthesis

Break

Methodology

- Anodic Oxidation
- Cathodic Reduction
- Paired Electrolysis
- Asymmetric Electrocatalysis
- Photo-electrochemistry

Electrochemistry

‘Electrochemistry relates the flow of electrons to chemical changes’



- last resort • non-standard • sheer desperation • lack of engineering savy • a quandry • tailor made • unpredictable • realm of specialists • expensive • precious metals •
- Intimate • visceral • raw redox-chemistry • do more with less • no reagent approach • dial in oxidative strength • green • precisely controlled • great promise • electrosynthesis gives organic chemists more power • resurgence • surrogate reagent • recyclable electrodes • tunability •

Electrochemistry

‘Many reactions can be accomplished using simple chemical oxidants...’

Could synthetic organic electrochemistry head into a ‘golden era of vibrant utility’?

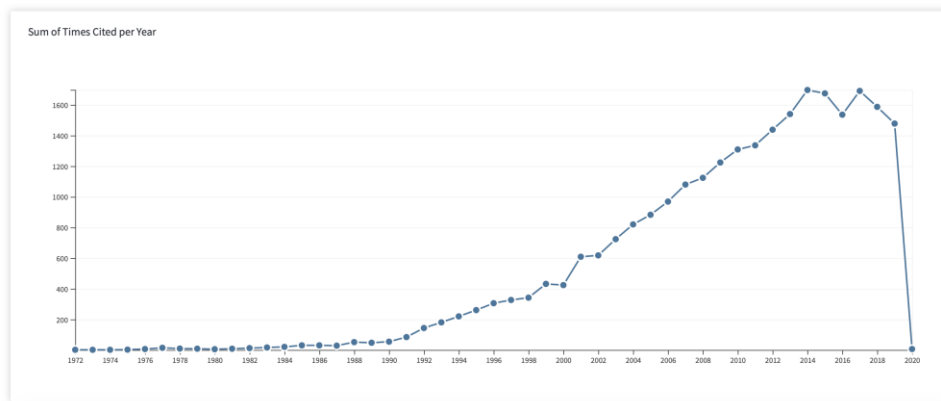

Milestones in Electrochemistry



Luigi Galvani



Alessandro Volta

“Each metal has a certain power, which is different from metal to metal, of setting the electric fluid in motion.”

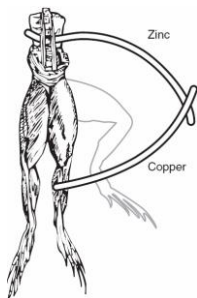

“animal electric fluid”
from the muscles
1786



+ 0.72 V per cell

“metallic electricity”
from connection of two wires
1794-1800

Milestones in Electrochemistry

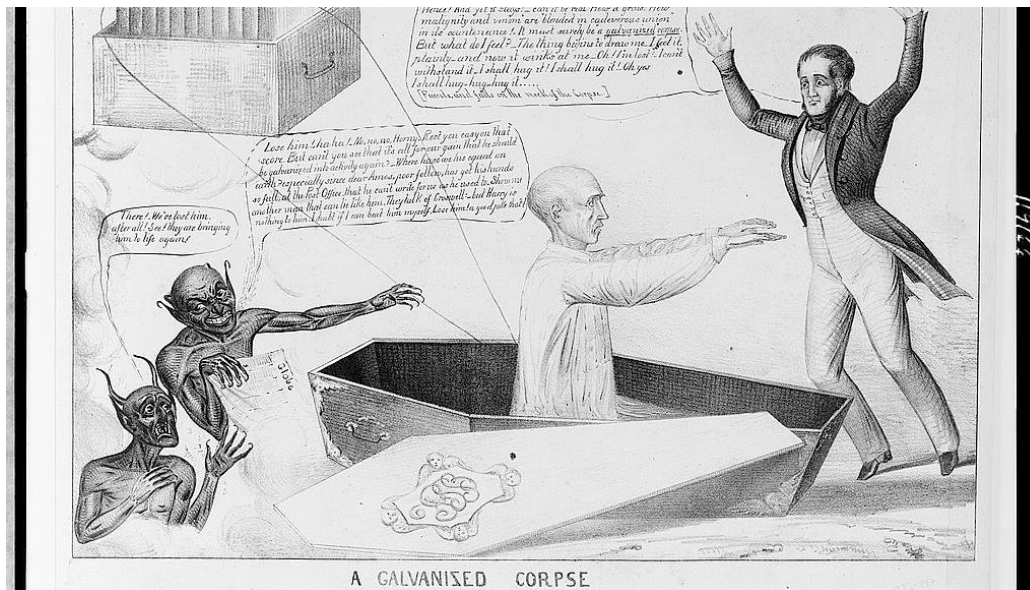

A Timeline of Electro-Organic chemistry

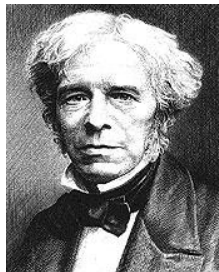

*“Astonishing how great the precautions that
are needed in these delicate
experiments. Patience. Patience.”*

Michael Faraday

A Timeline of Electro-Organic chemistry

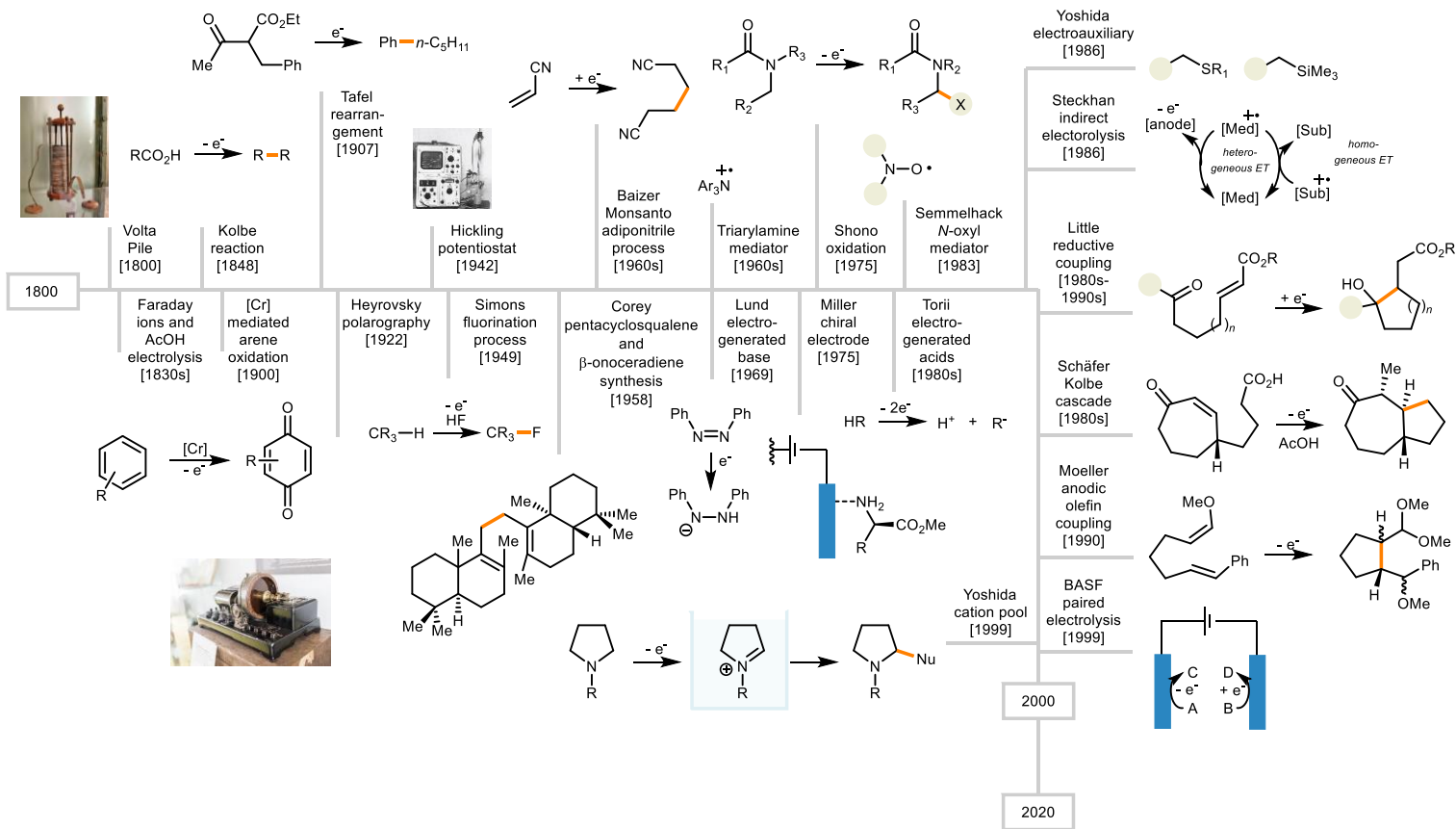

A Timeline of Electro-Organic chemistry

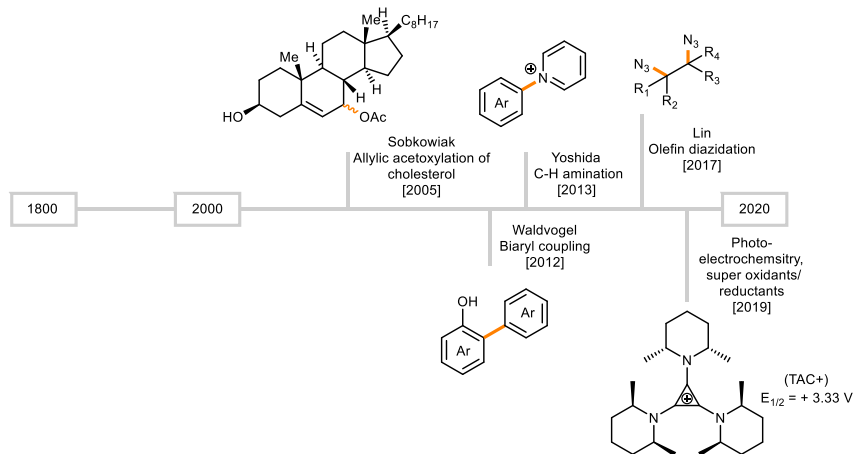

This Literature Review:

Select examples to highlight key transformations and techniques used in electro-organic synthesis

Underlying Theory

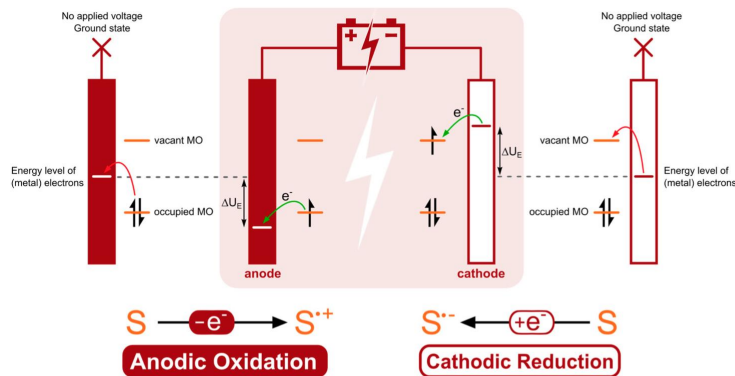
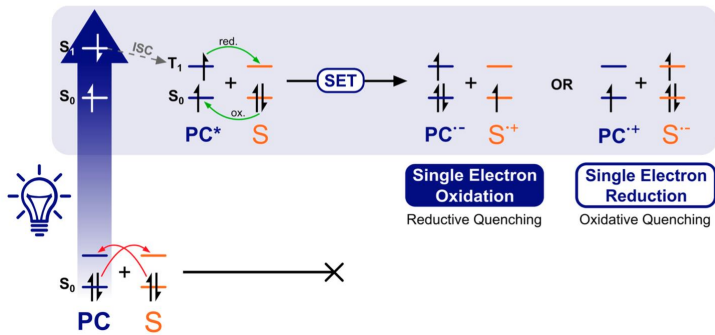

Photoredox Catalysis



Photoredox Catalysis

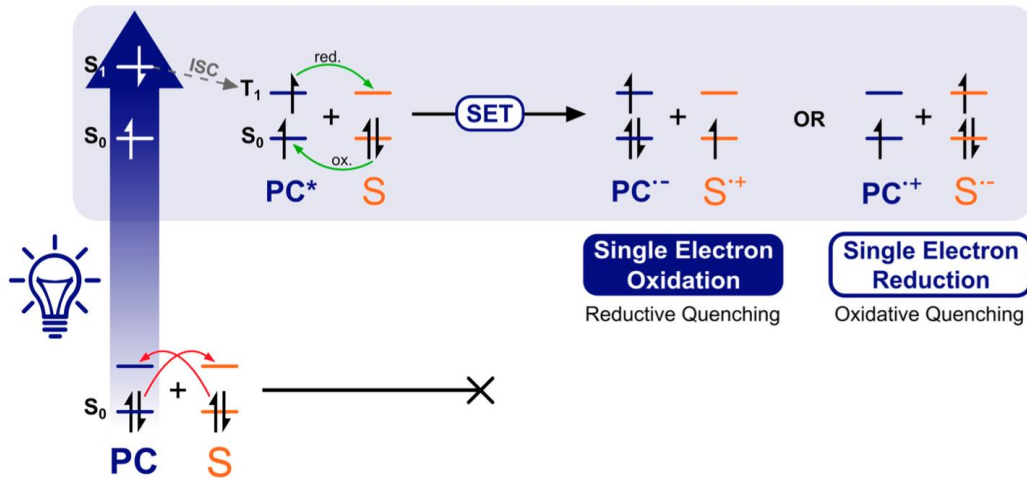

Electrochemistry

“The **Fermi Level** of a solid-state body is the thermodynamic work required to add one electron to the body.”

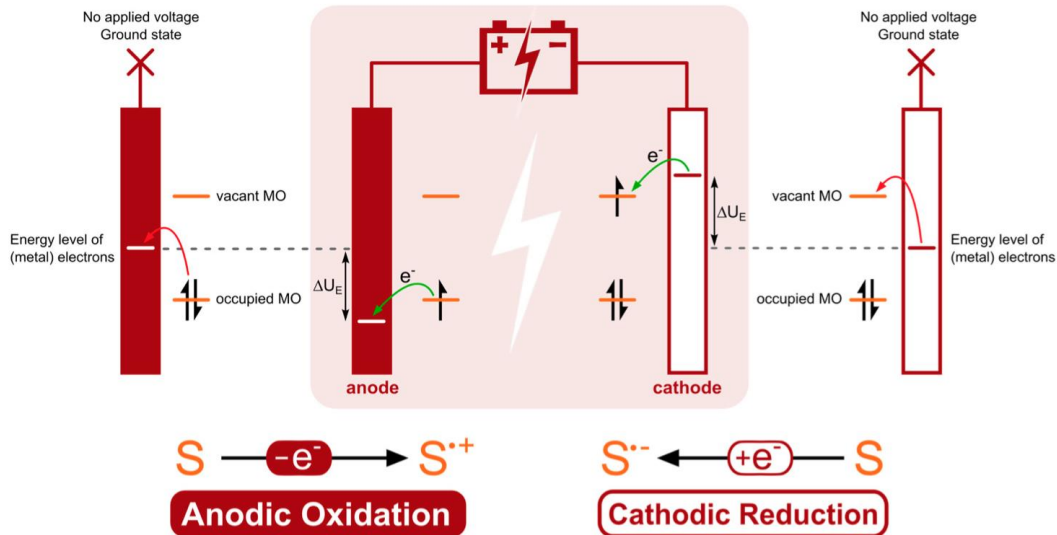

An Ox



Red Cat

A Comparison between Photoredox Catalysis and Electrochemistry



Photoredox Catalysis

- **Electron Transfer** - Homogeneous
- **Half Reactions** - Within once cycle
- **Selectivity** – Catalyst choice
- **Rate** – Loading, light intensity
- **Over reactivity** – Concentration, catalyst
- **Mild & Green & Cost**



Electrochemistry

- **Electron Transfer** - Heterogeneous
- **Half Reactions** - Two distinct locations
- **Selectivity** – Tunable potential, electrode choice
- **Rate** – Current, electrode, electrolyte
- **Over reactivity** – Total charge consumption (F/mol)
- **Mild & Green & Cost**

A Comparison between Photoredox Catalysis and Electrochemistry



Limitations



Photoredox Catalysis

- Light absorption - Beer-Lambert-Bouguer Law
- Sacrificial redox agents
- Photon energy limit

Beer-Lambert-Bouguer law



$$A = \epsilon \cdot c \cdot d = \log \frac{I_0}{I}$$

$$A \sim d$$

$$I \sim 10^{-\epsilon \cdot c \cdot d}$$

Electrochemistry

- Solvent potential window
- Ohmic drop – Double layer, diffusion controlled

Ohmic drop

$$\Delta E_{\text{ohm}} = -I \cdot R_{\text{cell}} \text{ with } R_{\text{cell}} = \frac{d}{\rho \cdot A}$$



$$\Delta E_{\text{ohm}} \sim d$$

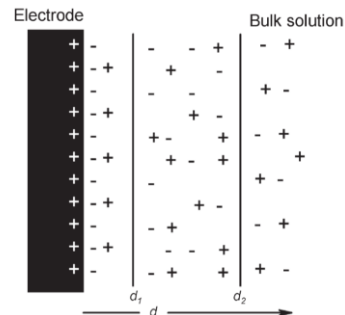

Key Equations

Nernst Equation

$$E_{cell} = E_{cell}^{\circ} - \frac{RT}{nF} \ln Q$$



$$\Delta G = -nF\Delta E_{cell} < 0$$

$$\Delta E^{cell} = E_{reduced} - E_{oxidised} > 0$$

Review Outline

Introduction

- Organic Electrochemistry
- Key Milestones
- Underlying theory

Practicalities & Applications

- Experimental Parameters
- Electrolysis Methods
- Applications
 - Industrial Processes
 - Natural Product Synthesis

Break

Methodology

- Anodic Oxidation
- Cathodic Reduction
- Paired Electrolysis
- Asymmetric Electrocatalysis
- Photo-electrochemistry

Experimental Parameters

Un-divided Cell

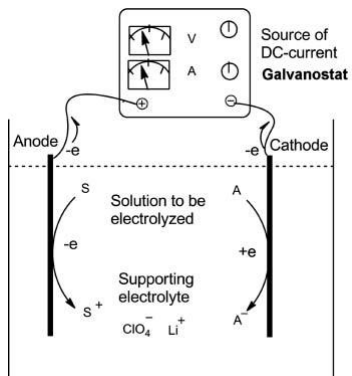

- First choice
- Easy to set up

Divided Cell

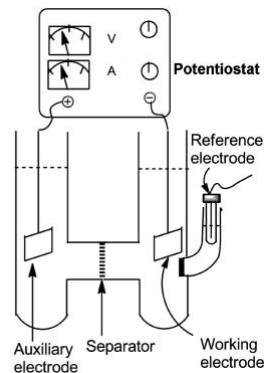

- Higher resistance
- Inconvenient
- Useful when product reacts at opposite electrode

(A) constant current

- First choice (2 - 10 mA, 2 - 4 F/mol, 0.1 - 0.3 mmol)
- Better conversion, sometimes over-reaction

(V) constant potential

- Lower conversion
- Higher selectivity

Experimental Parameters

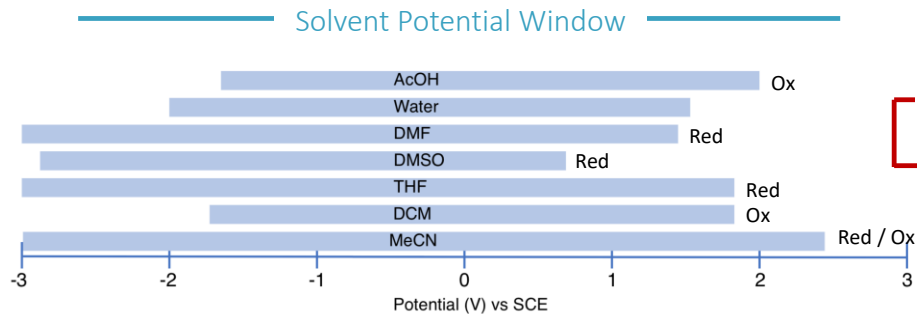

Unsuitable Solvents
benzene, toluene, hexane

Supporting Electrolyte

Concentration: [0.1 – 0.5 M]

Cation: Li^+ , R_4N^+

Anion: ClO_4^- , BF_4^- , triflate, halide

Electrode Material

1 H Hydrogen 1.008																	2 He Helium 4.002602						
3 Li Lithium 6.94	4 Be Beryllium 9.0121831																						
		Atomic Number →		1		← Symbol																	
		Name →		Hydrogen		← Atomic Weight																	
5 B Boron 10.81	6 C Carbon 12.011	7 N Nitrogen 14.007	8 O Oxygen 15.999	9 F Fluorine 18.99840323	10 Ne Neon 20.1797																		
11 Na Sodium 22.98976928	12 Mg Magnesium 24.305																						
13 Al Aluminum 26.9815385	14 Si Silicon 28.085	15 P Phosphorus 30.973761998	16 S Sulfur 32.06	17 Cl Chlorine 35.45	18 Ar Argon 39.948																		
19 K Potassium 39.0983	20 Ca Calcium 40.078	21 Sc Scandium 44.955908	22 Ti Titanium 47.88	23 V Vanadium 50.9415	24 Cr Chromium 51.9961	25 Mn Manganese 54.938044	26 Fe Iron 55.845	27 Co Cobalt 58.933195	28 Ni Nickel 58.6934	29 Cu Copper 63.546	30 Zn Zinc 65.38	31 Ga Gallium 69.723	32 Ge Germanium 72.630	33 As Arsenic 74.921595	34 Se Selenium 78.971	35 Br Bromine 79.904	36 Kr Krypton 83.798						
37 Rb Rubidium 85.4678	38 Sr Strontium 87.62	39 Y Yttrium 88.90584	40 Zr Zirconium 91.224	41 Nb Niobium 92.90637	42 Mo Molybdenum 95.95	43 Tc Technetium (98)	44 Ru Ruthenium 101.07	45 Rh Rhodium 102.90550	46 Pd Palladium 106.42	47 Ag Silver 107.8682	48 Cd Cadmium 112.414	49 In Indium 114.818	50 Sn Tin 118.710	51 Sb Antimony 121.760	52 Te Tellurium 127.603	53 I Iodine 126.90447	54 Xe Xenon 131.293						
55 Cs Caesium 132.90545196	56 Ba Barium 137.327	57 - 71 Lanthanoids	72 Hf Hafnium 178.49	73 Ta Tantalum 180.94788	74 W Tungsten 183.84	75 Re Rhenium 186.207	76 Os Osmium 190.23	77 Ir Iridium 192.227	78 Pt Platinum 195.084	79 Au Gold 196.966569	80 Hg Mercury 200.59	81 Tl Thallium 204.38	82 Pb Lead 207.2	83 Bi Bismuth 208.98040	84 Po Polonium (209)	85 At Astatine (210)	86 Rn Radon (222)						
87 Fr Francium (223)	88 Ra Radium (226)	89 - 103 Actinoids	104 Rf Rutherfordium (261)	105 Db Dubnium (268)	106 Sg Seaborgium (269)	107 Bh Bohrium (270)	108 Hs Hassium (269)	109 Mt Meitnerium (278)	110 Ds Darmstadtium (281)	111 Rg Roentgenium (282)	112 Cn Copernicium (285)	113 Nh Nihonium (286)	114 Fl Flerovium (289)	115 Mc Moscovium (289)	116 Lv Livermorium (293)	117 Ts Tennessine (294)	118 Og Oganesson (294)						

57 La Lanthanum 138.90547	58 Ce Cerium 140.16	59 Pr Praseodymium 140.90766	60 Nd Neodymium 144.242	61 Pm Promethium (145)	62 Sm Samarium 150.36	63 Eu Europium 151.964	64 Gd Gadolinium 157.25	65 Tb Terbium 158.92535	66 Dy Dysprosium 162.50	67 Ho Holmium 164.93033	68 Er Erbium 167.259	69 Tm Thulium 168.93422	70 Yb Ytterbium 173.045	71 Lu Lutetium 174.9668
89 Ac Actinium (227)	90 Th Thorium 232.0377	91 Pa Protactinium 231.03688	92 U Uranium 238.02891	93 Np Neptunium (237)	94 Pu Plutonium (244)	95 Am Americium (243)	96 Cm Curium (247)	97 Bk Berkelium (247)	98 Cf Californium (251)	99 Es Einsteinium (252)	100 Fm Fermium (257)	101 Md Mendelevium (258)	102 No Nobelium (259)	103 Lr Lawrencium (260)

 Electrodes

 High H₂ overpotential

 Photoanodes

Experimental Parameters

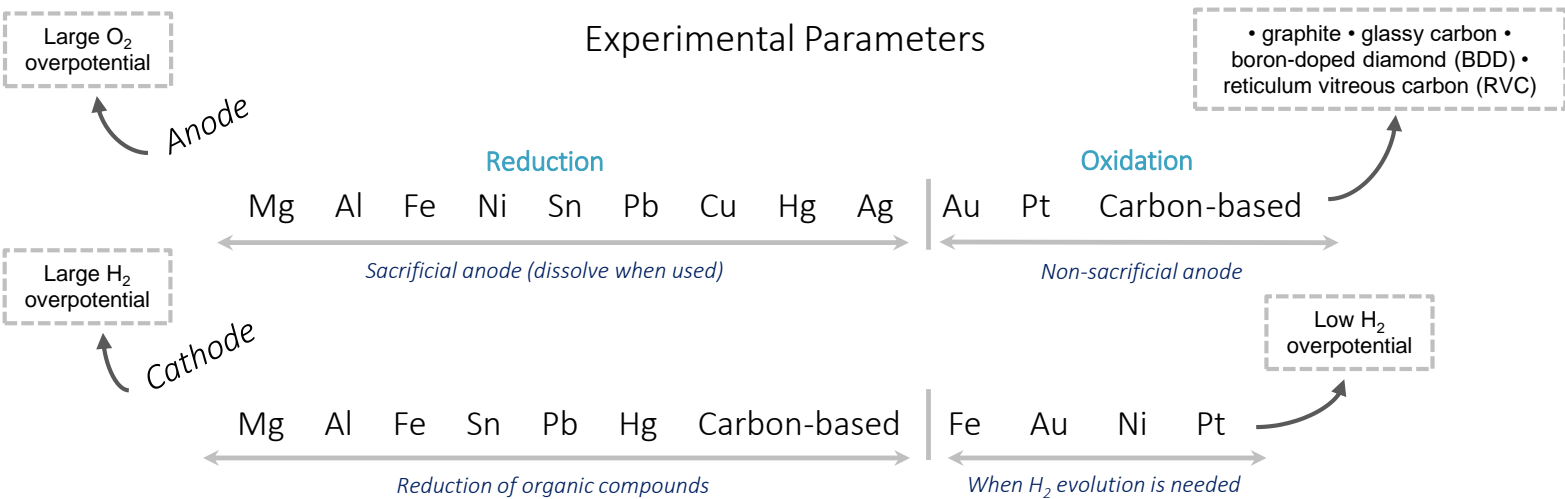

“Electrodes are merely the surfaces or doors by which the electricity enters into or passes out of the substances suffering decomposition.”

Michael Faraday, **1833**

Experimental Parameters

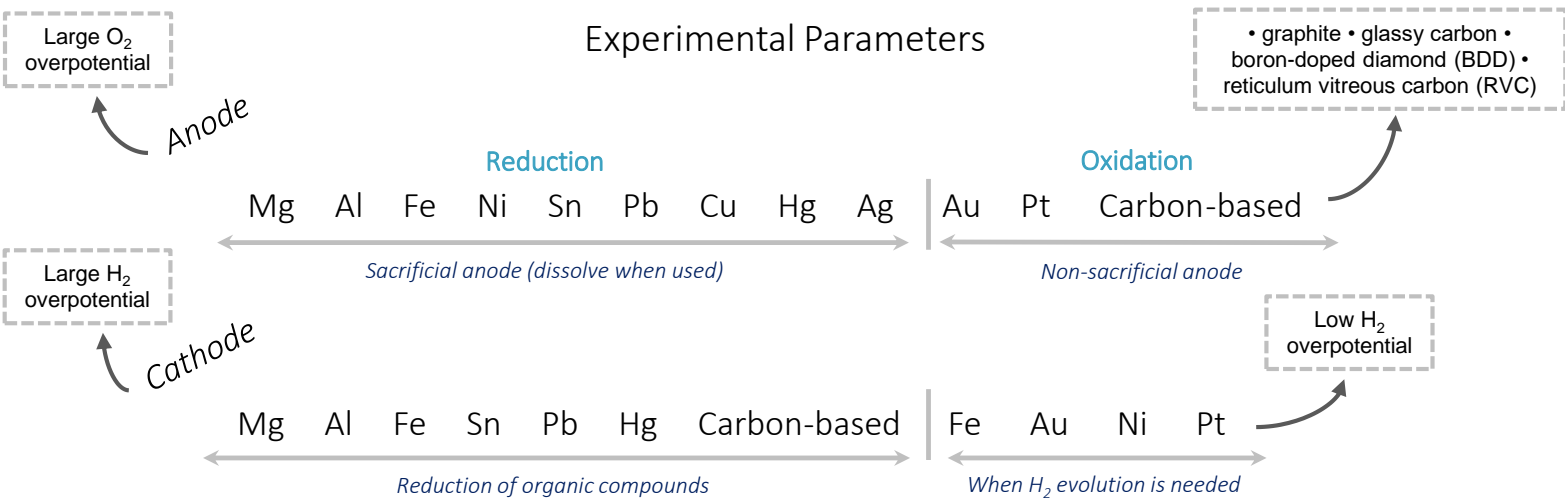

Reference Electrodes

Standard Hydrogen Electrode (SHE) $E = 0.000 \text{ V}$

Saturated Calomel Electrode (SCE) $E = 0.241 \text{ V}$

Cu/CuSO₄ electrode (CSE) $E = 0.314 \text{ V}$

Ag/AgCl electrode $E = 0.197 \text{ V}$

Experimental Parameters

Redox Potentials

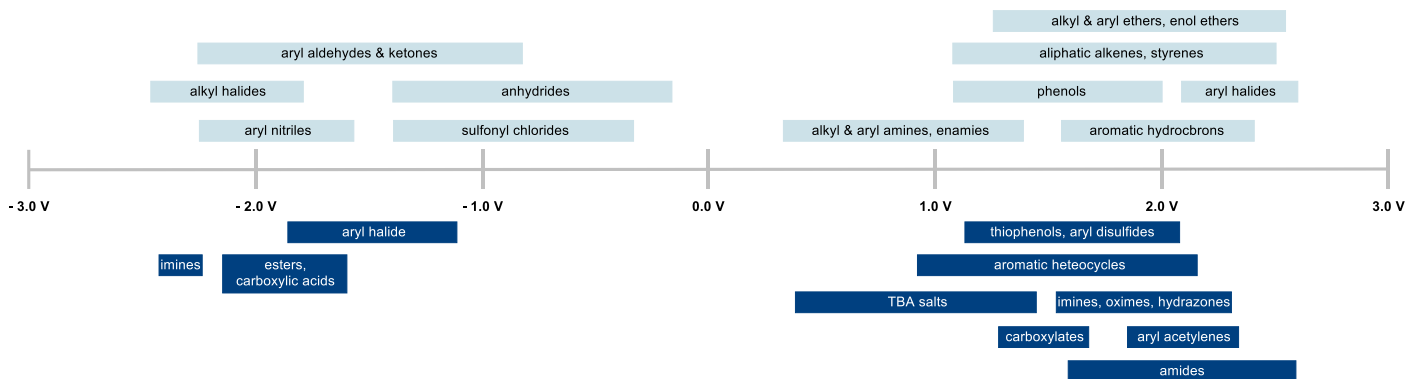

Cyclic Voltammetry

IPUAC Convention

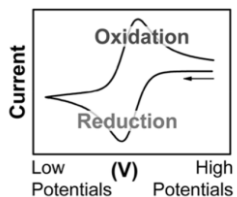

- Measure reduction potentials at a fixed current
- Reversible / Irreversible / Quasi-reversible processes
- Ferrocene ($Fc / Fc^+ = 0.45 \text{ V}$) internal standard in organic solvents (MeCN)

Electrolysis Methods in Organic Chemistry

D Direct Electrolysis

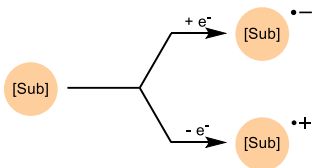

- Direct electrolysis by electrodes
- Heterogeneous electron transfer

M Mediated Electrolysis

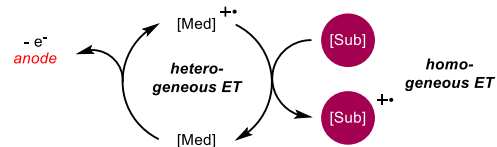

- Mediators act as electron carriers
- Homogeneous electron transfer (photoredox like)
- Increase in reaction rate
- Supporting electrolyte is indispensable

C Cation Pool Method

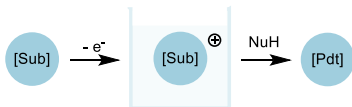

- Low temperature generates and accumulates reactive species

E Electro-Generated Reagents

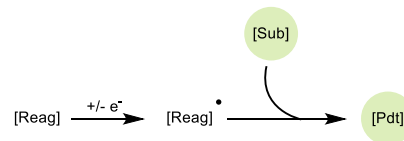

Industrial Applications of Electrochemistry



Aluminium

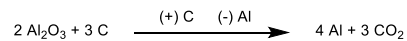

Chlor-Alkali Industry

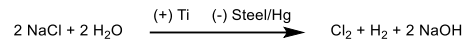

acetoin
BASF

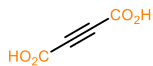

acetylenedicarboxylic acid
BASF

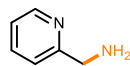

2-aminomethylpyridine
Reilly Tar

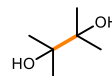

pinacol
BASF



adiponitrile
BASF, Monsanto

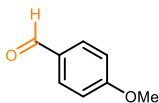

p-anisaldehyde
BASF, Monsanto

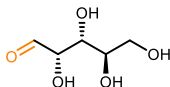

arabinose
Electrosynthesis Co.

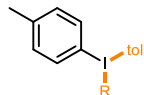

ditolylidonium salts
Eastman Chemical



ditolylidonium salts
BASF

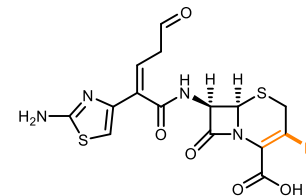

ceftibuten
Electrosynthesis Co.

Electrochemistry in Natural Product Synthesis

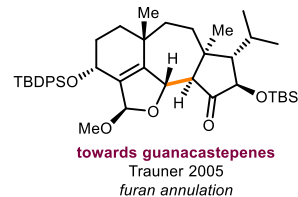
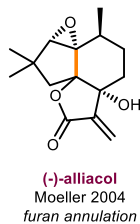
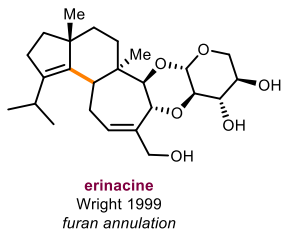
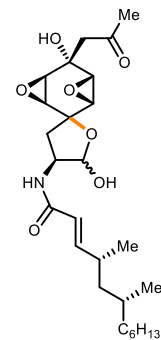
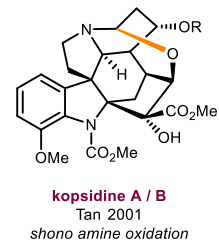
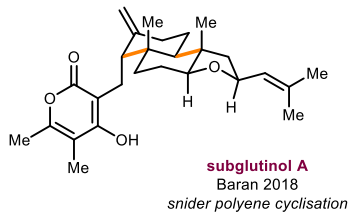
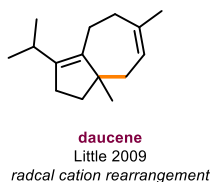
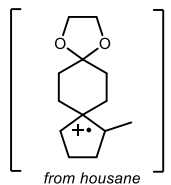
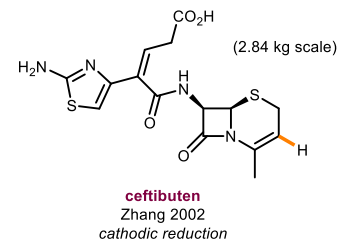
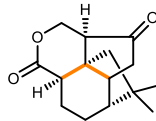
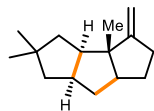
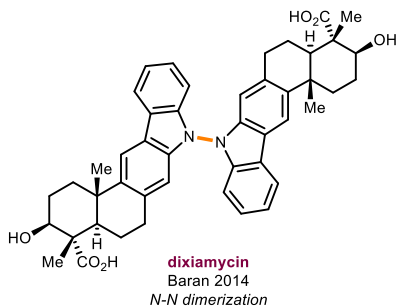

Natural Products: Case Studies

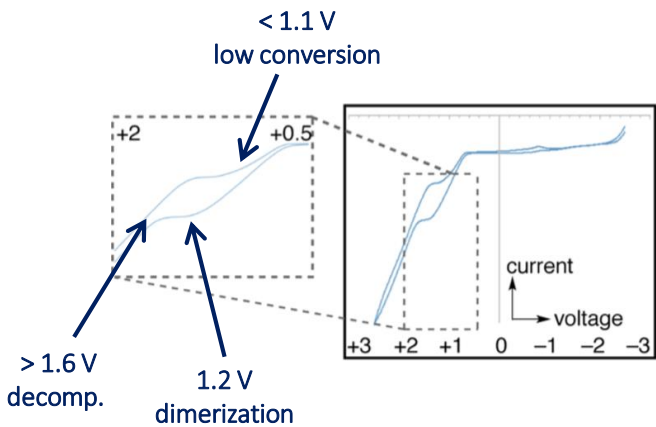
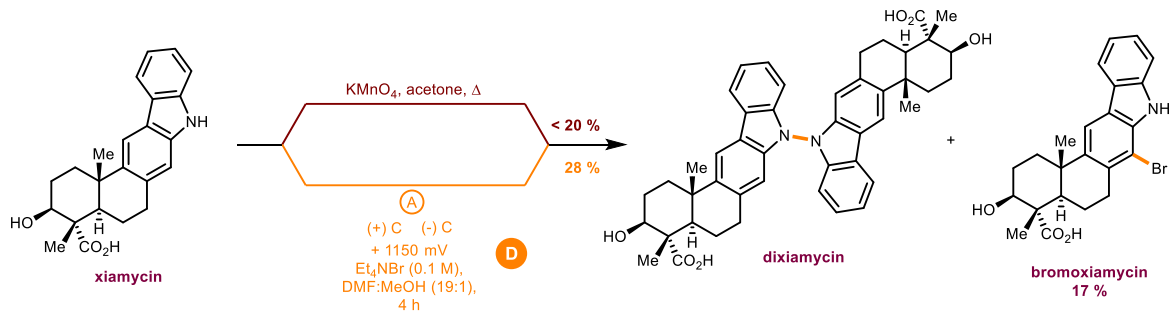

N-N dimerization Scope

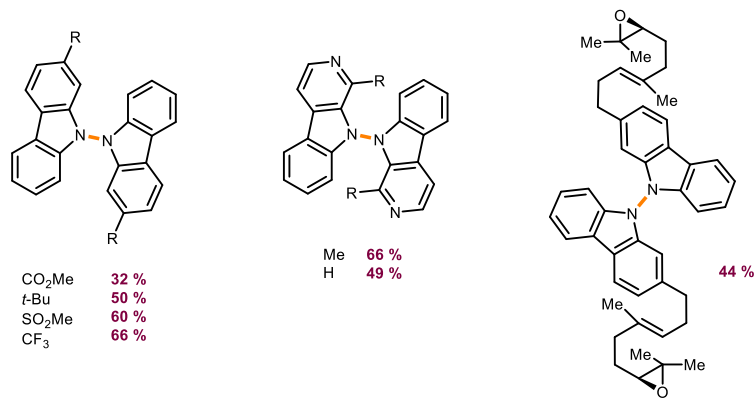

Natural Products: Case Studies



Marasmius alliaceus

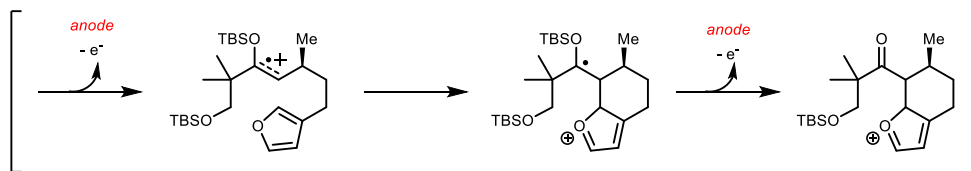
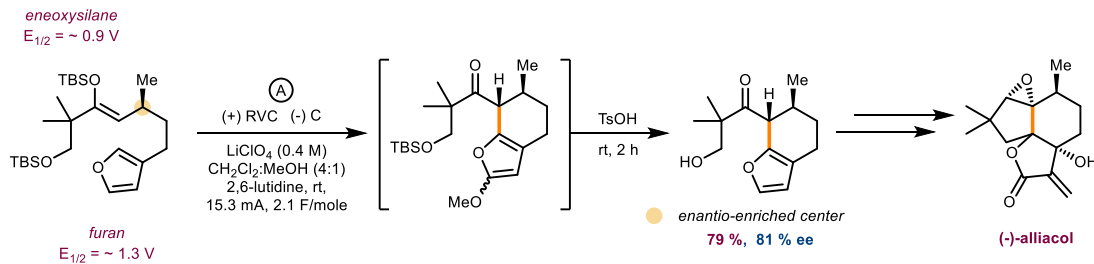

Natural Products: Case Studies



Penicillium purpurogenum

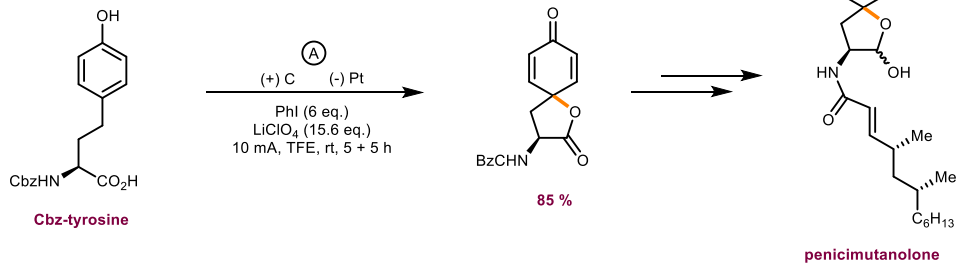

E

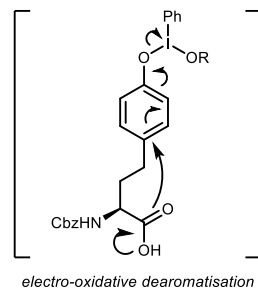
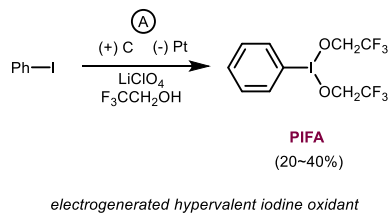

Review Outline

Introduction

- Organic Electrochemistry
- Key Milestones
- Underlying theory

Practicalities & Applications

- Experimental Parameters
- Electrolysis Methods
- Applications
 - Industrial Processes
 - Natural Product Synthesis

Break

Methodology

- Anodic Oxidation
- Cathodic Reduction
- Paired Electrolysis
- Asymmetric Electrocatalysis
- Photo-electrochemistry

Anodic Oxidation

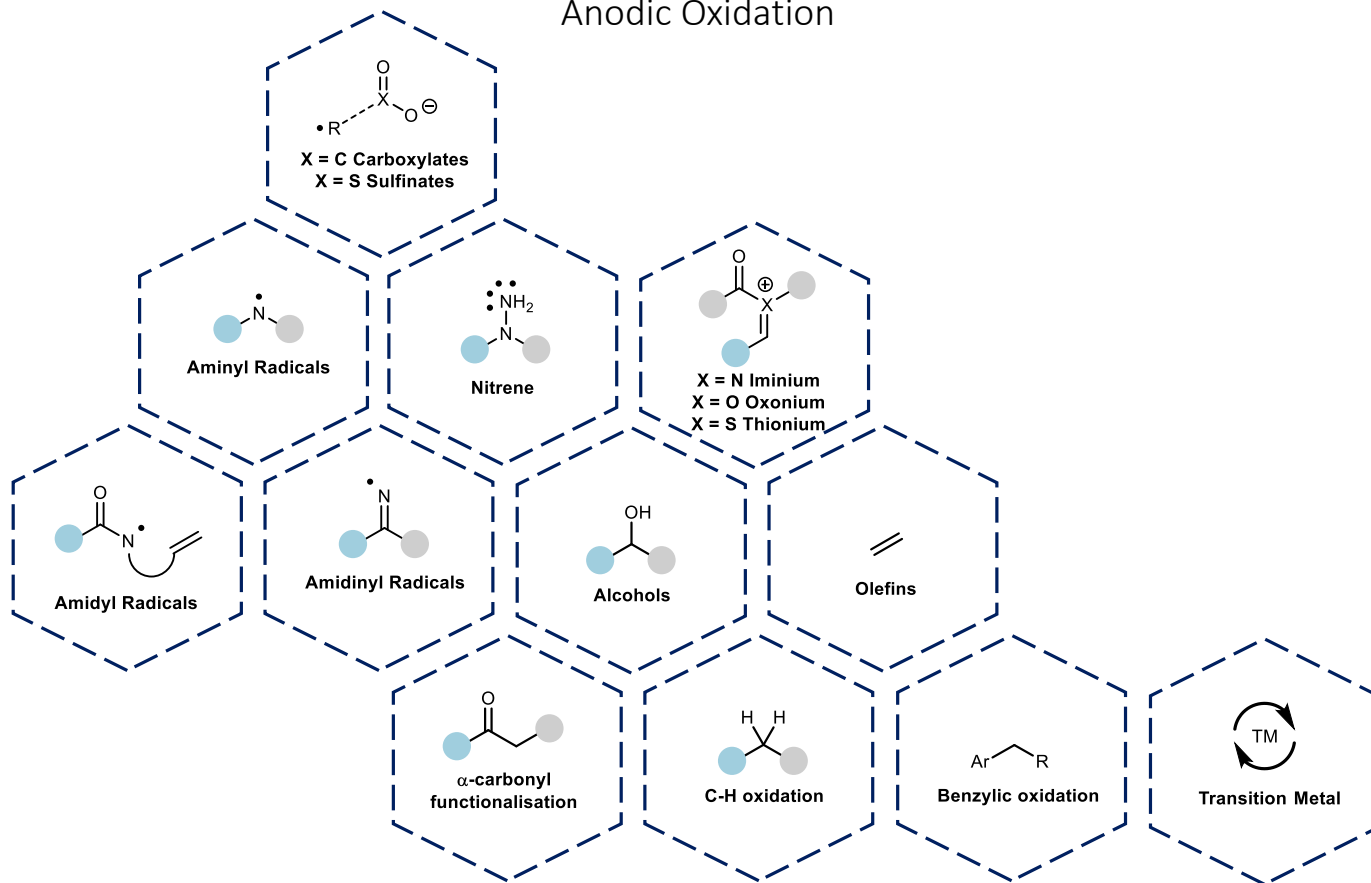

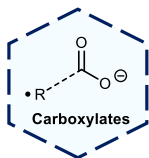

Anodic Oxidation

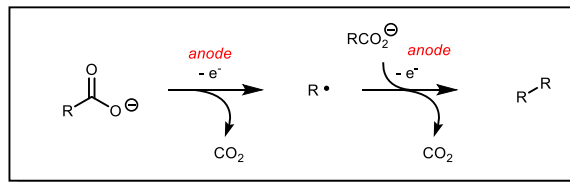

• Kolbe

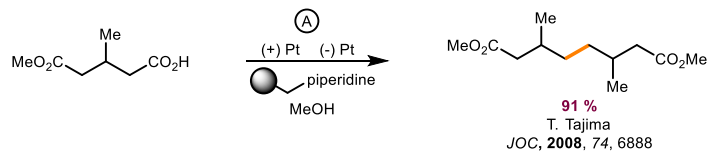

7 examples
44 - 99 %

D

• Mixed-Kolbe

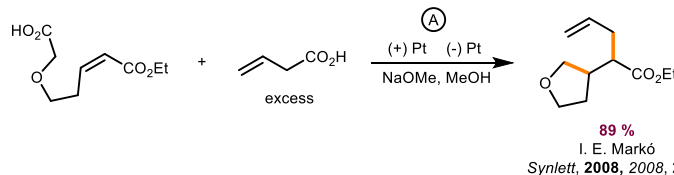

15 examples
16 - 90 %

D

• Non-Kolbe

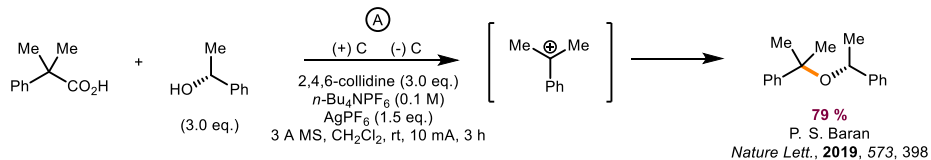

83 examples
14 - 95 %
Nu = KF, CN, CO₂H

D

Secondary oxidation to cationic intermediate

• fragmentation • rearrangement • elimination • nucleophilic addition •

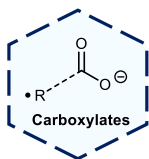

Anodic Oxidation

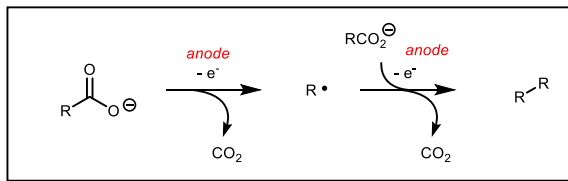

- Solvent effect on reactive intermediate

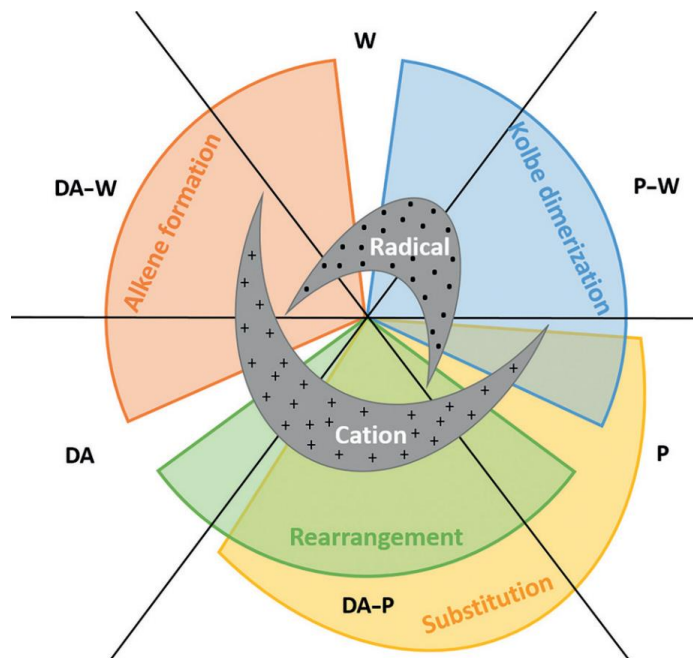

W water
P protic
DA dipolar aprotic

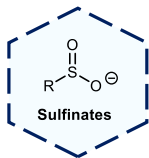

Anodic Oxidation

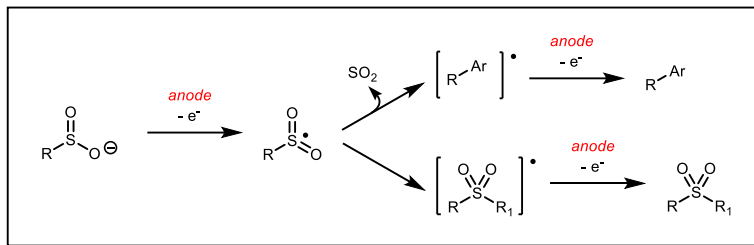

• Sulfonyl radical

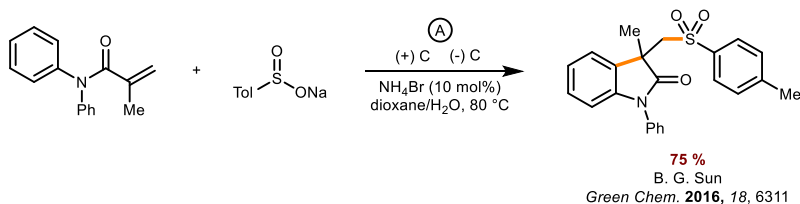

15 examples
48 - 85 %

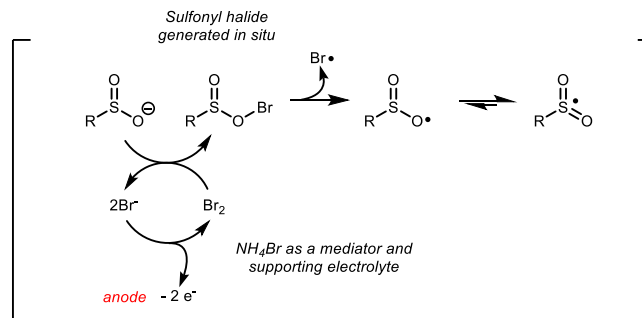

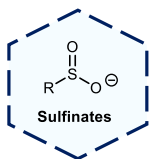

Anodic Oxidation

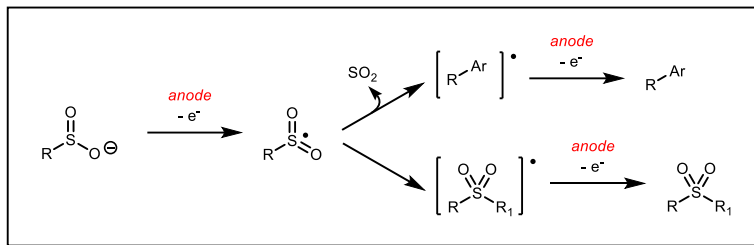

• Sulfonyl radical

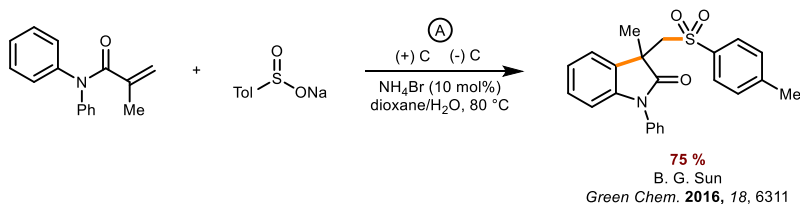

15 examples
48 - 85 %

M

• Alkyl radical

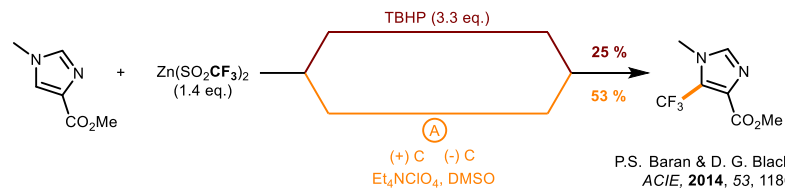

24 examples
15 - 92 %

E

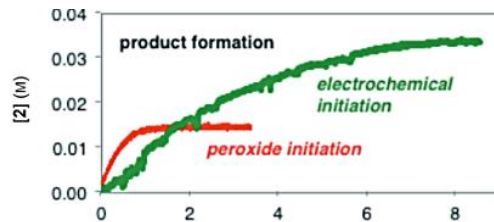

Anodic Oxidation

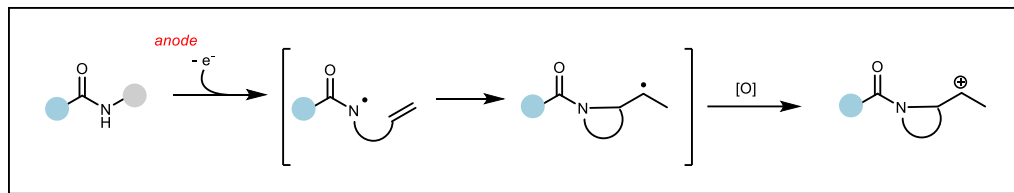
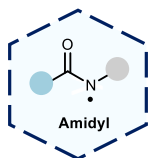
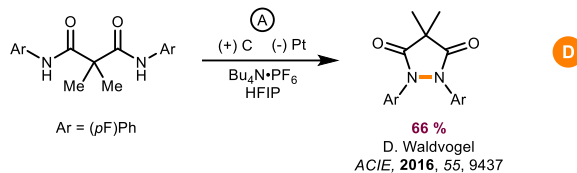
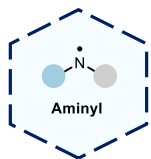

• *elimination* • *nucleophilic addition* • *H-atom abstraction* •

Direct Electrolysis

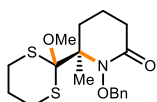

Nu addition
K. D. Moeller
JOC, **2014**, 79, 379

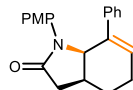

Elimination
H. C. Xu
JACS, **2017**, 139, 2956

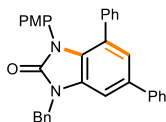

Oxidative
H. C. Xu
ACIE, **2019**, 58, 9017

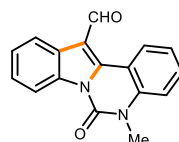

Oxidative
H. C. Xu
ACIE, **2016**, 55, 9168

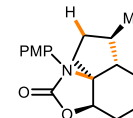

H-atom source
H. C. Xu
ACIE, **2016**, 55, 2226

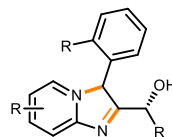

Oxidative
H. C. Xu
Beilstein *JOC*, **2019**, 15, 795

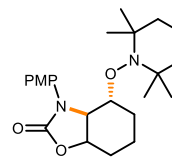

Nu addition
H. C. Xu
Chem. Eur. J. **2014**, 20, 12740

Mediated Electrolysis

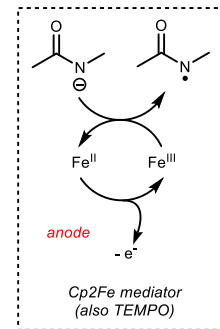

Anodic Oxidation

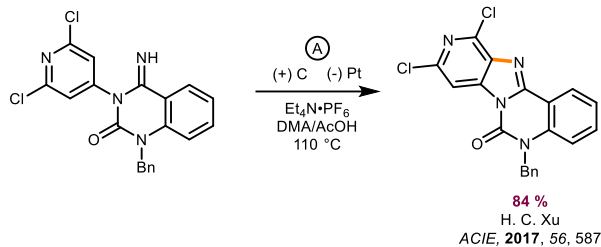
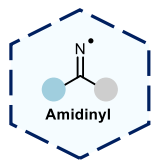

D

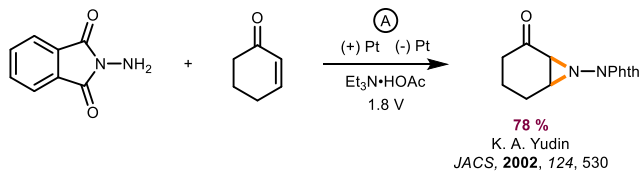
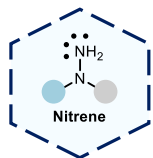

D

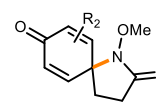
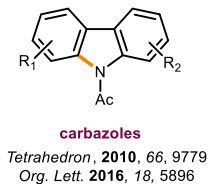
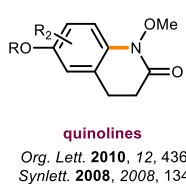
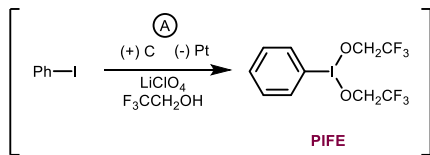
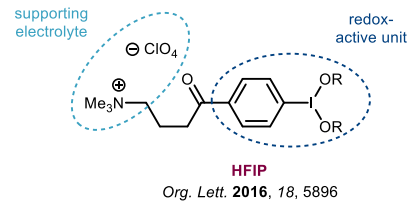
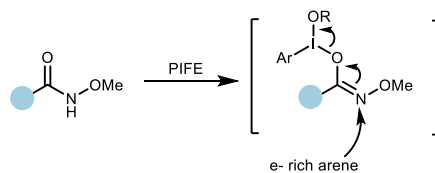
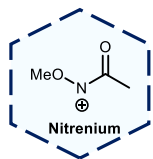

spirocycles
Tet. Lett. **2006**, 47, 6505

E



Anodic Oxidation

- Shono Oxidation

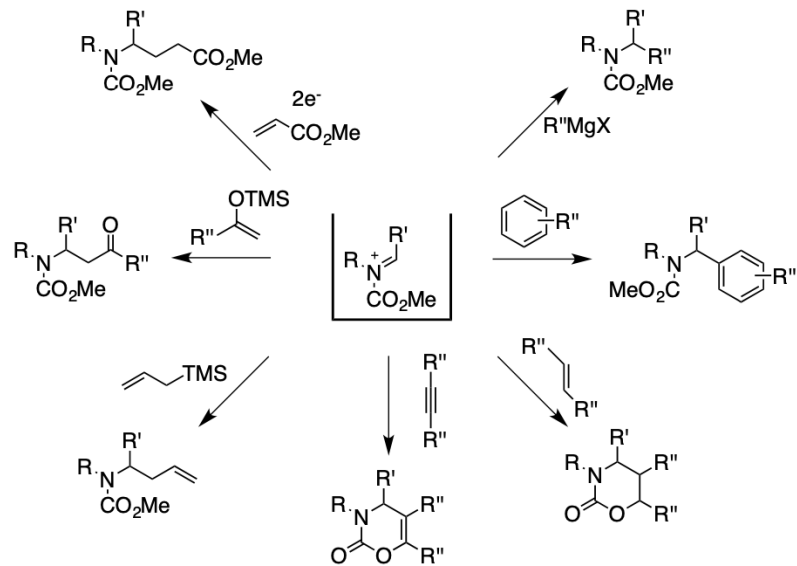

C

Cation Pool Method

- cryogenic temperatures accumulates cationic intermediates
- reduced oxidation of nucleophile
- prevents over oxidation of product



Anodic Oxidation

- Shono Oxidation - electroauxiliaries

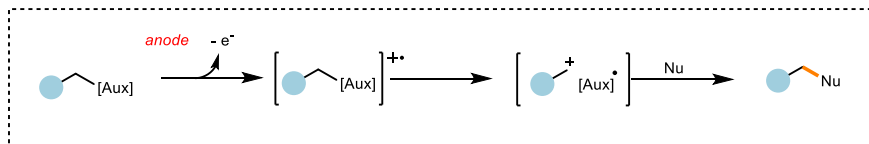

- lowers redox potential
- prevents solvent oxidation
- prevents over-oxidation
- chemo- and regio- control

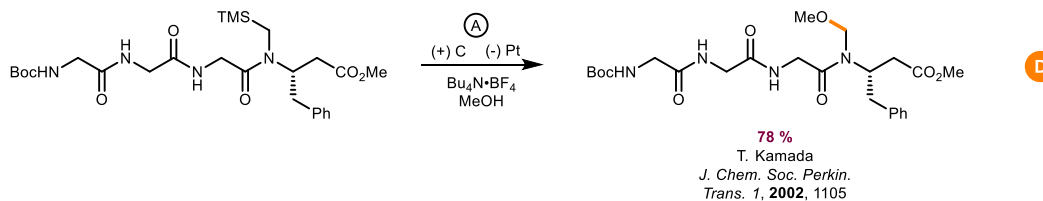
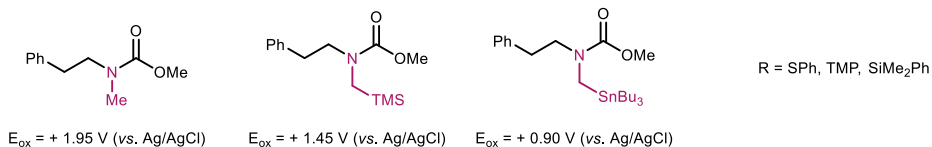



Anodic Oxidation

- Related Intermediates

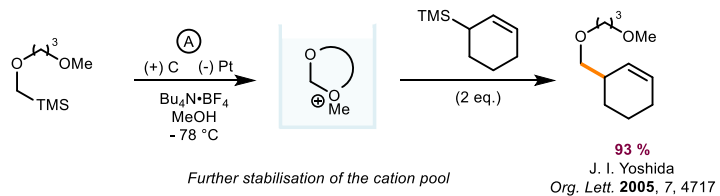
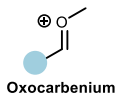

C

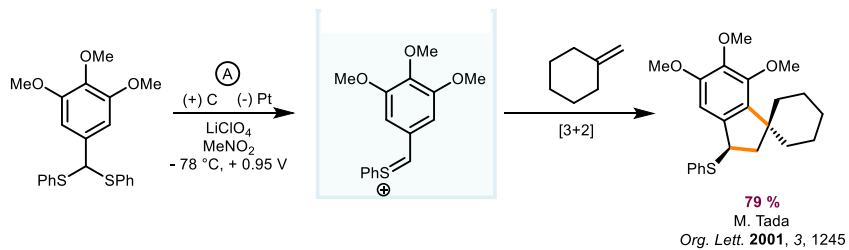

C

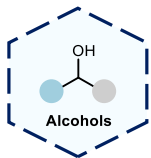

Anodic Oxidation

- Double Mediator Systems

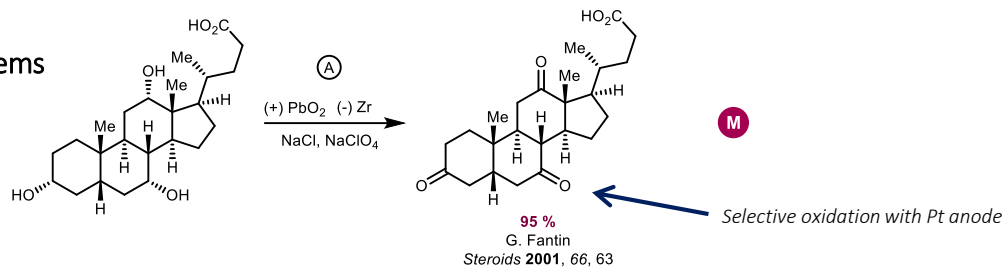

Requires nitroxyl mediators

- sparingly soluble in polar media
- double mediatory systems
- biphasic solvent mixture / emulsions
- polymer support
- electrode anchoring

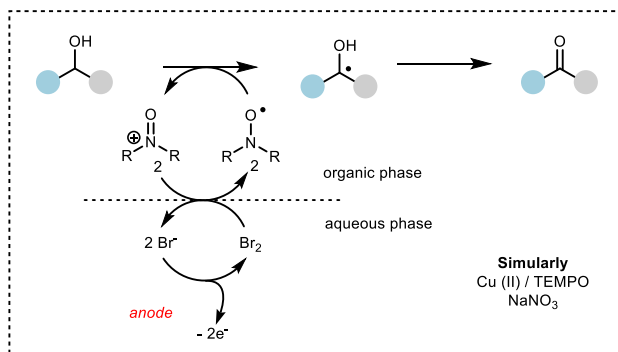

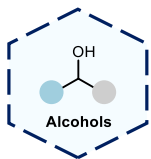

Anodic Oxidation

- Double Mediator Systems

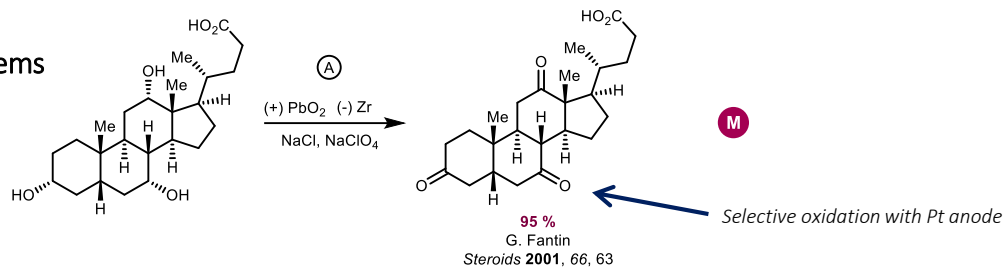

Requires nitroxyl mediators

- sparingly soluble in polar media
- double mediatory systems
- biphasic solvent mixture / emulsions
- polymer support
- electrode anchoring

- Alkoxy Radicals

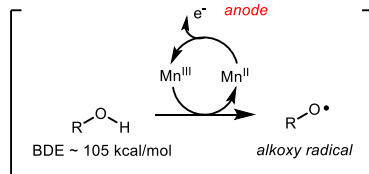
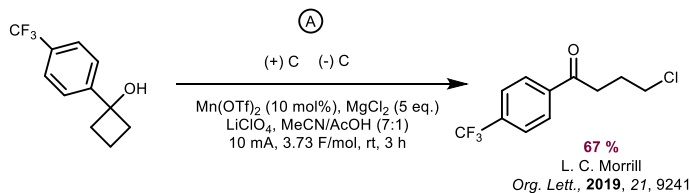

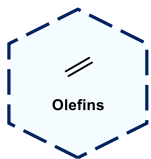

Anodic Oxidation

- Cycloadditions

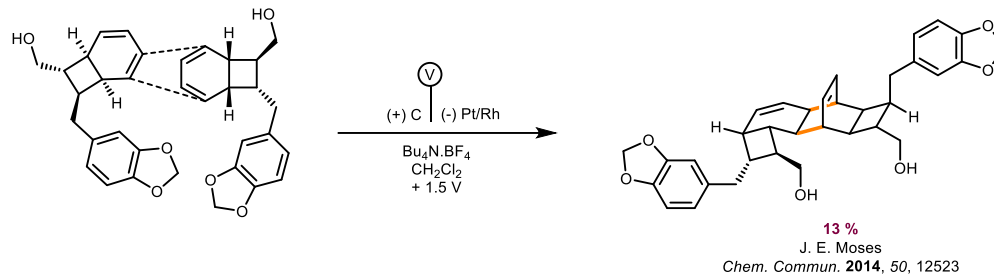

- Cross-Metathesis

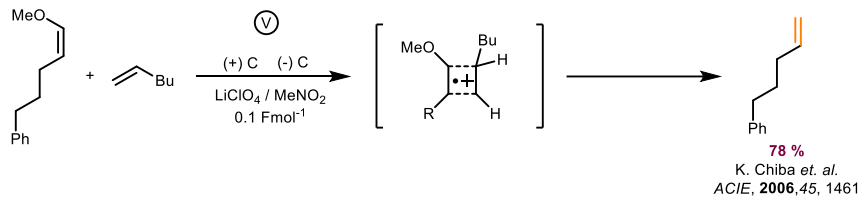

- Diazidation

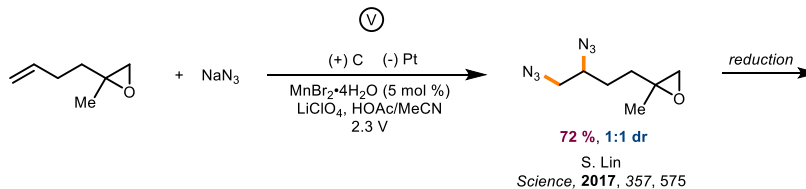

• *inexpensive Mn catalyst* • *potentiostatic conditions allow high chemoselectivity* •

Anodic Oxidation

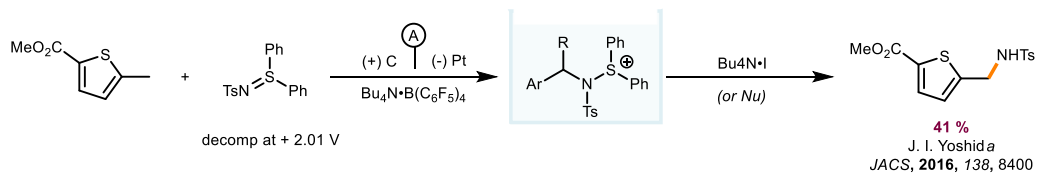
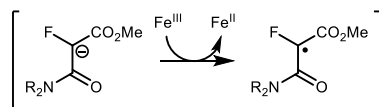
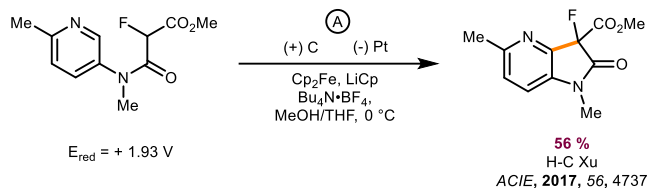
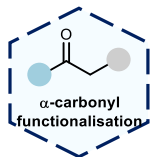

- benzylic cations unstable at $-78 \text{ }^\circ\text{C}$ (unlike di-aryl cations) •
- cation pool prevents overoxidation •

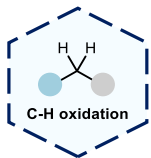

- Allylic C—H

Anodic Oxidation

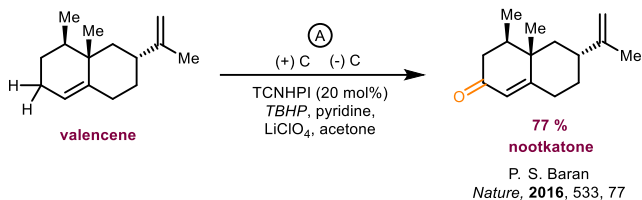

- improved yields over Cr, Rh or Se • up to 100 g scale • 40 examples

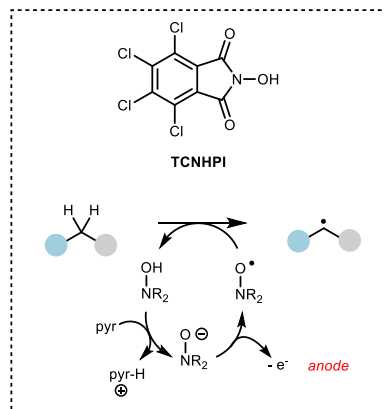

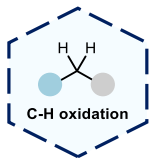

- Allylic C—H

Anodic Oxidation

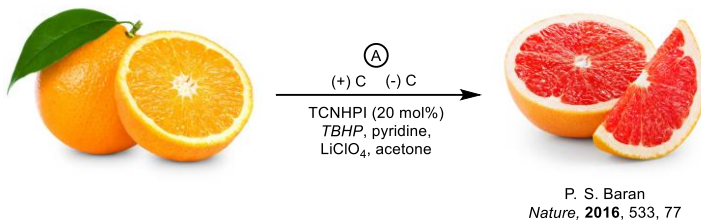

400 tonnes of grapefruit = 1 kg

P450 enzymatic oxidation
(Oxford Biotrans)

- Methylene C—H

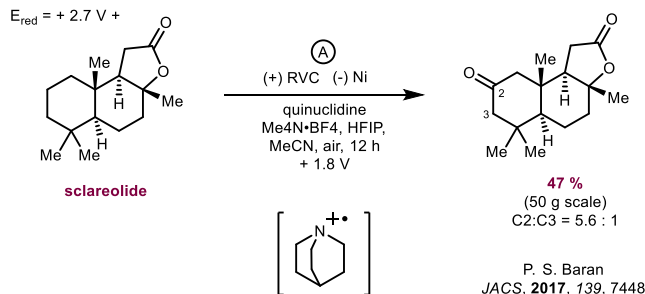

- mediator choice important
- scalable
- selectivity dependent on steric and electronic factors

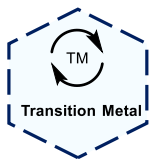

Anodic Oxidation

- C—H Functionalisation

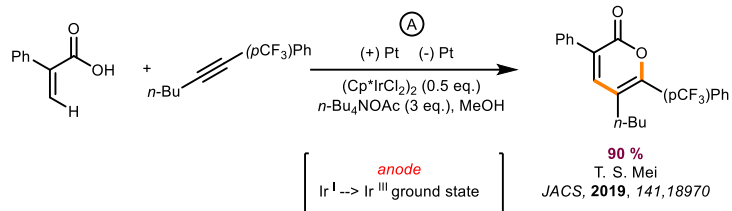

67 examples

Chemical oxidants:
 Cu(OAc)₂, Ag₂CO₃, PhI(OAc)₂
 < 18 % yield

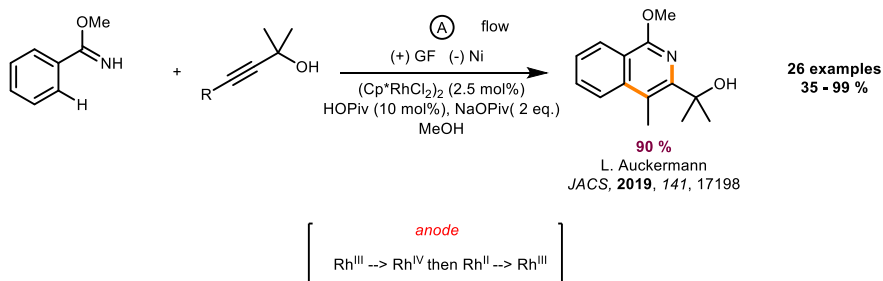
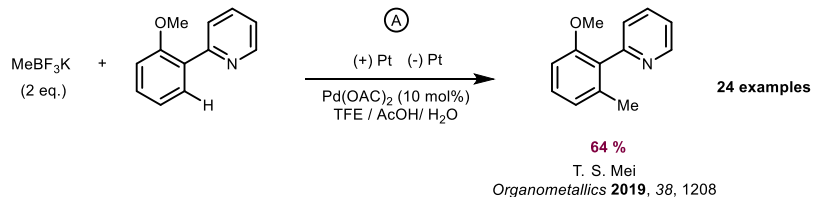

Cathodic Reduction

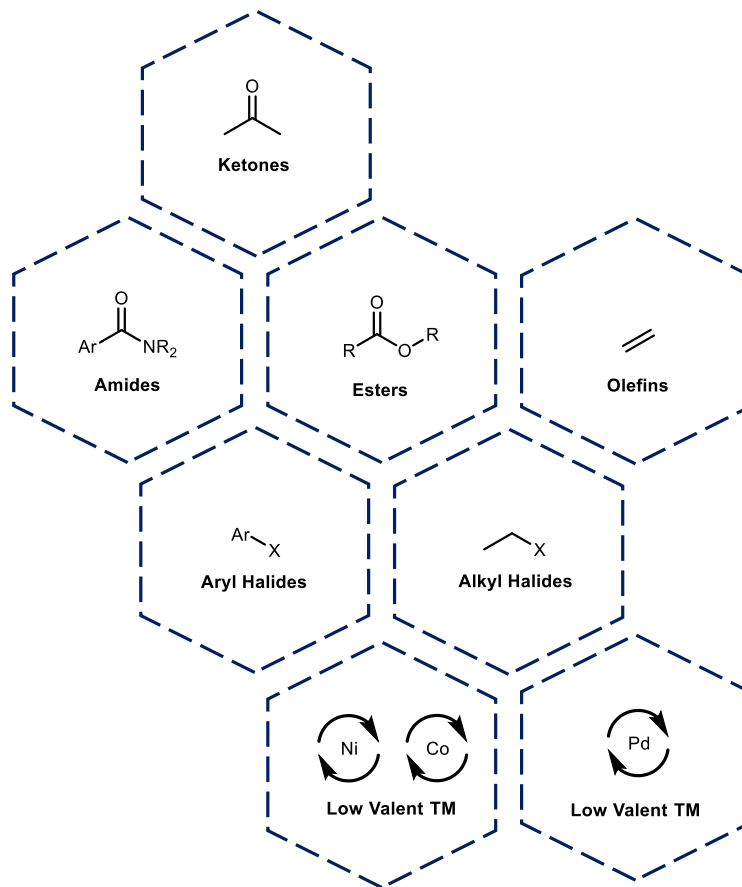

Cathodic Reduction

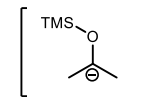
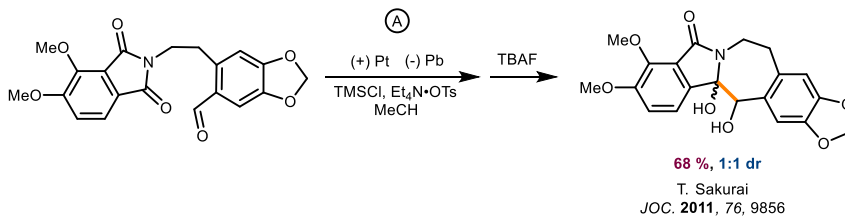
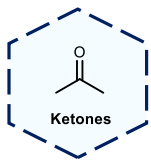

• TMS lowers redox potential•

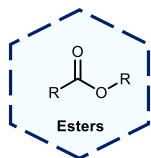
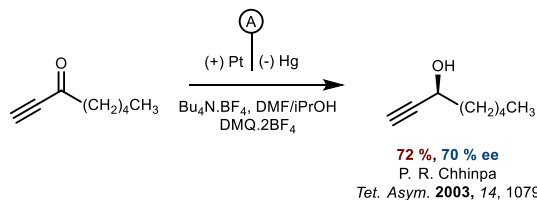
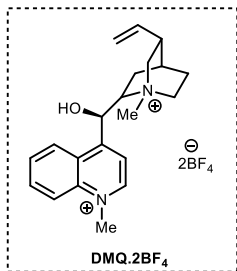
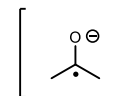

• not reduced with Zn, Pb, Ni, Cu, Pt or C •

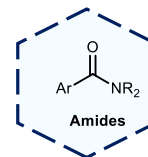

• requires acidic media •

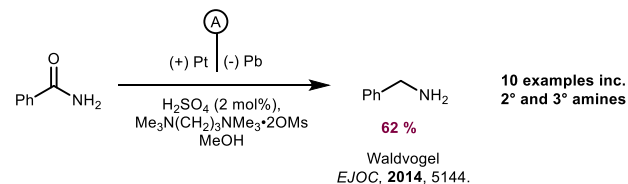
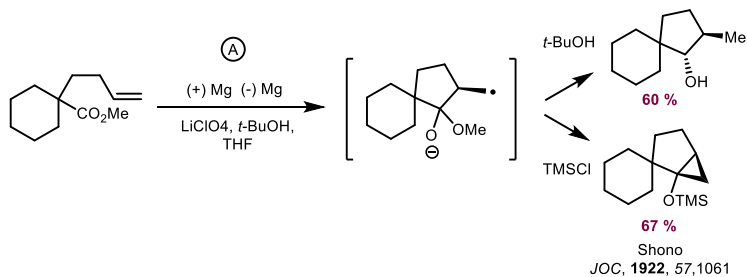

10 examples inc.
2° and 3° amines

Cathodic Reduction

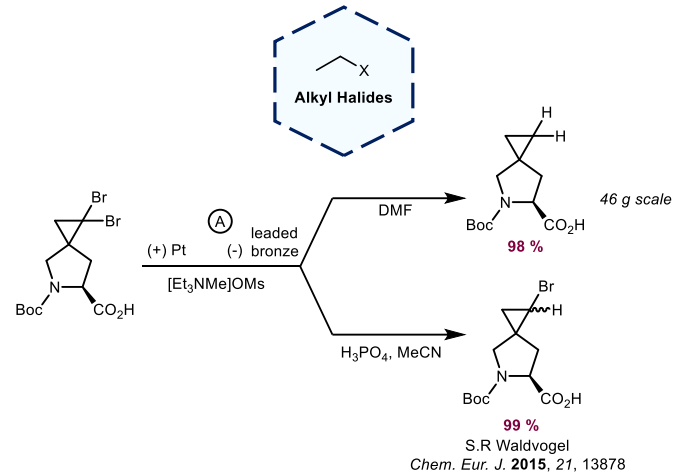
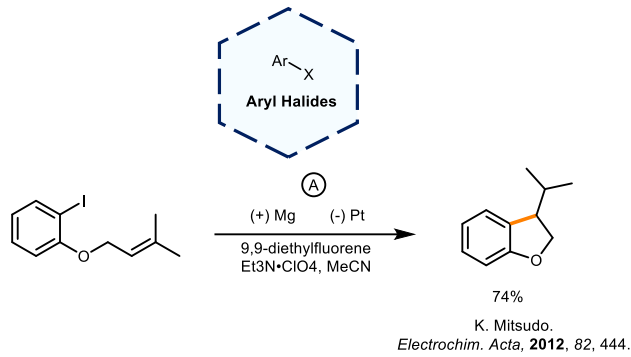

- *leaded bronze higher resistance to corrosion*
- *racemisation & ring opening with chemical reagents*

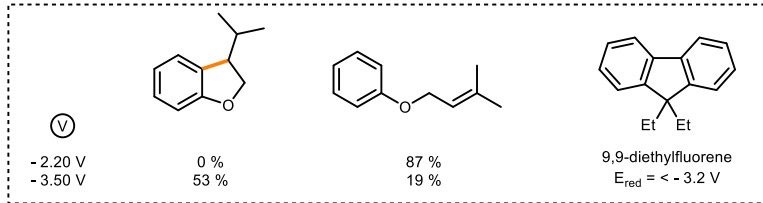

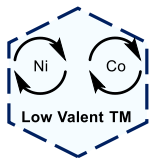

Cathodic Reduction

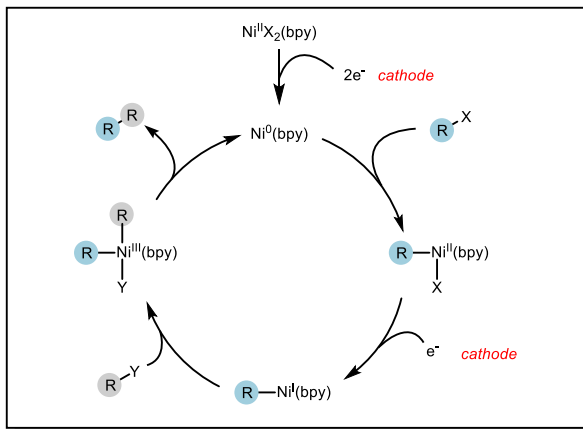

Low valent transition metal species as mediators

• Co(I) • Ni(I) •

Aryl Halides

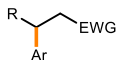

Conjugate addition

C. Ma

Electrochim. Acta, **2015**, 151, 284

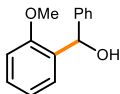

Nozaki-Hiyama-Kishi coupling

J. Perichon

Org. Lett. **2001**, 3, 2073

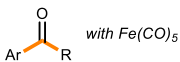

Ketone synthesis

J. Nédélec

Tetrahedron, **2001**, 57, 525

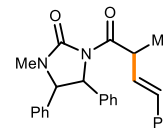

Alkyl-X

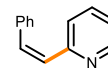

(Het)Ar-X

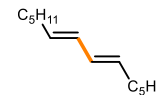

Homocoupling

J. Nédélec
JOC, **2000**, 65, 4575

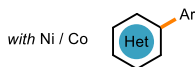

Heteroaryl halides

J. Perichon

Tet. Lett. **2000**, 41, 201

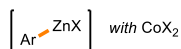

Transmetalation to Zn

J. Perichon

JOC, **2000**, 65, 6024

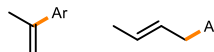

Cross electrophile coupling

J. Perichon

J. Org. Chem. **2003**, 68, 1142
Tetrahedron, **2003**, 59, 2999

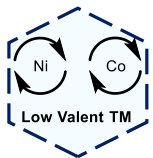

Cathodic Reduction

Recent highlights

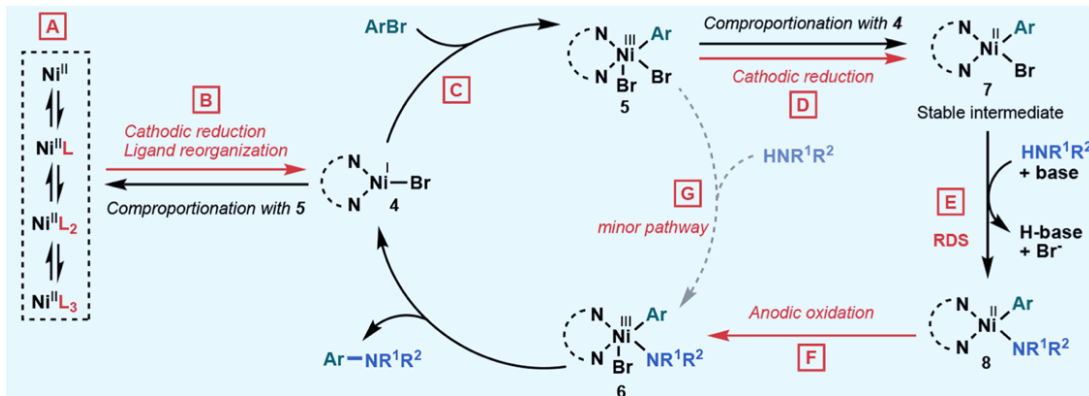
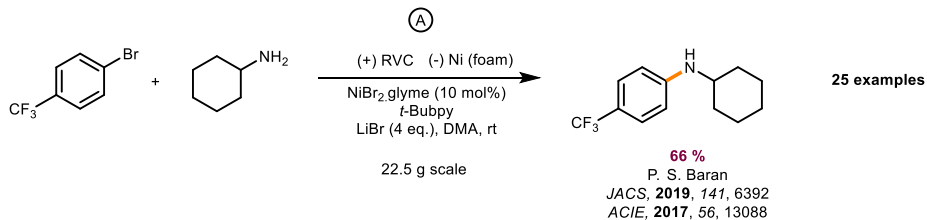
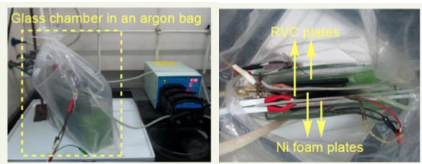
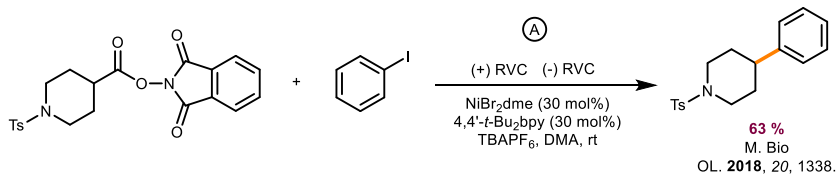

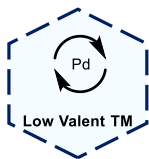

Cathodic Reduction

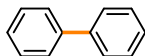
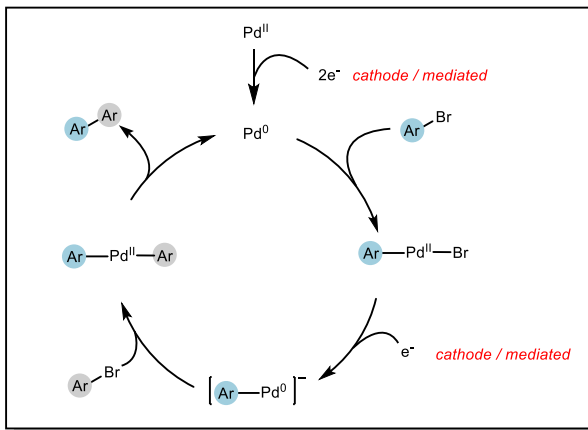

Homocoupling of aryl halides
 G. Rothenberg
Adv. Synth. Catal. **2006**, 348, 1705
 H. Tanaka
Tet. Lett. **2013**, 54, 3666

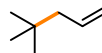

Allylation of alkyl halides
 J. M. Huang
Org. Lett. **2017**, 19, 2022

Electrochemically assisted Heck Reaction

- no ligand
- no high temperatures

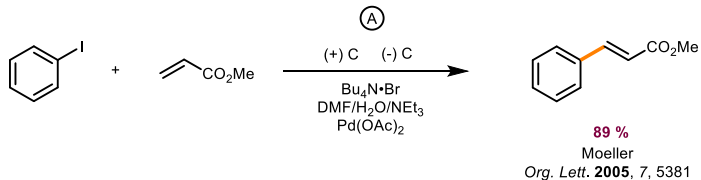

Paired Electrolysis

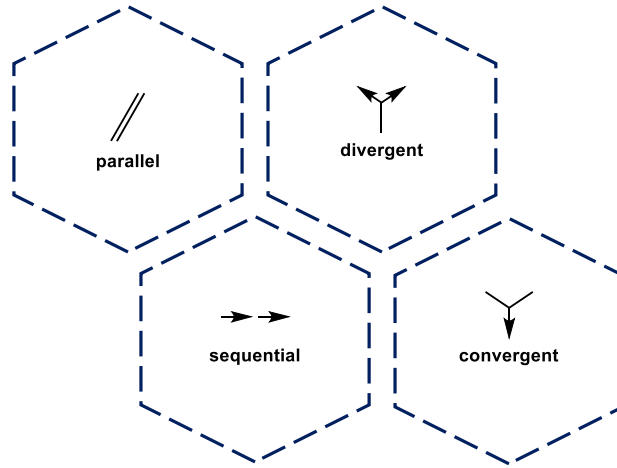

Paired Electrolysis

'Choreographed electrochemical processes where two desirable half reactions are performed simultaneously'

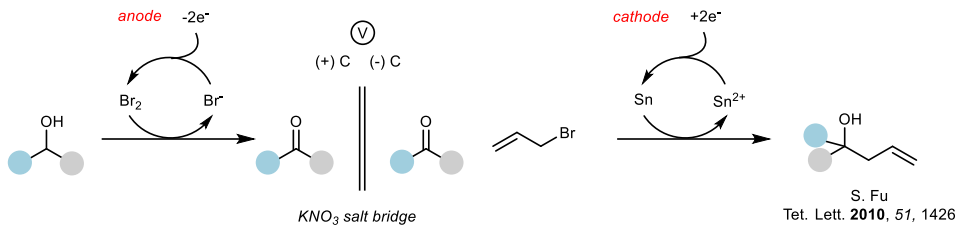
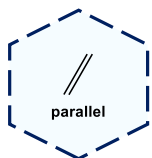

Two simultaneous and non-interfering half reactions

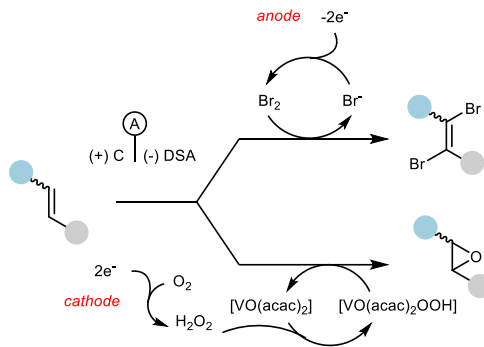

Two alternative reactions at each electrode

Paired Electrolysis

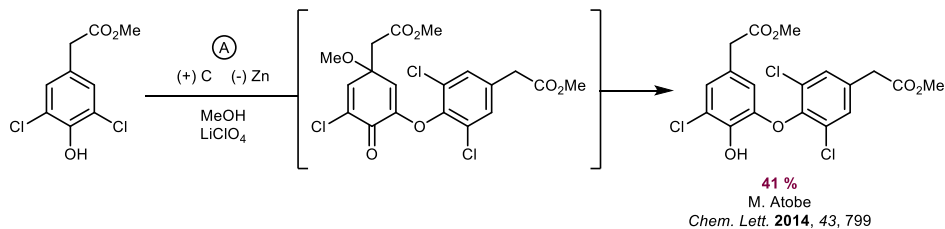
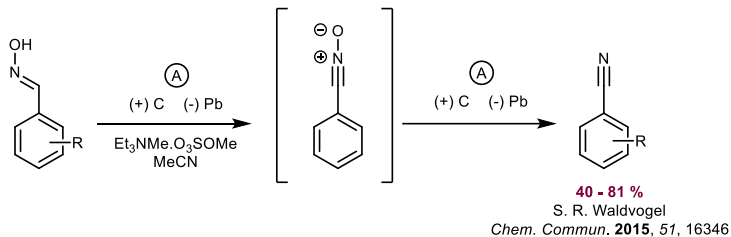
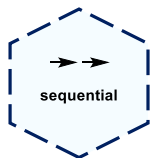

Sequential oxidations and reductions

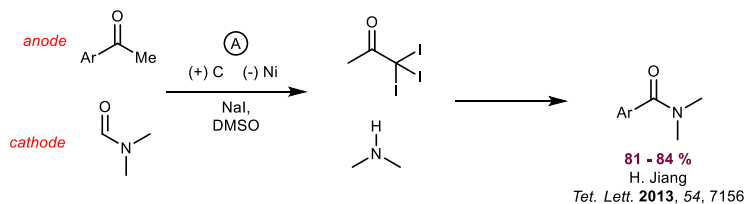
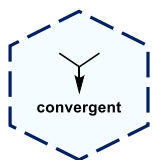

Anodically and cathodically generated intermediates react to afford the product

Asymmetric Electrochemical Catalysis

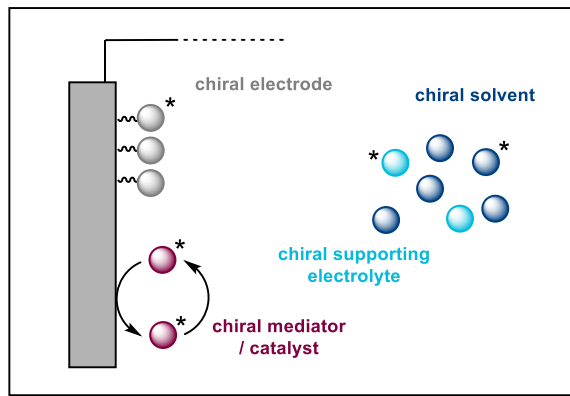

*...mostly unsuccessful...
generation of a 'chiral double-layer'*

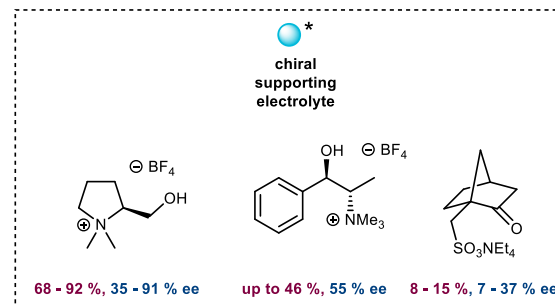
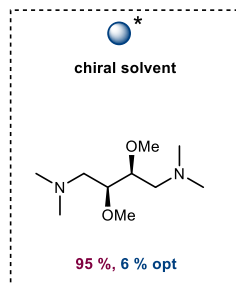

Asymmetric Electrochemical Catalysis

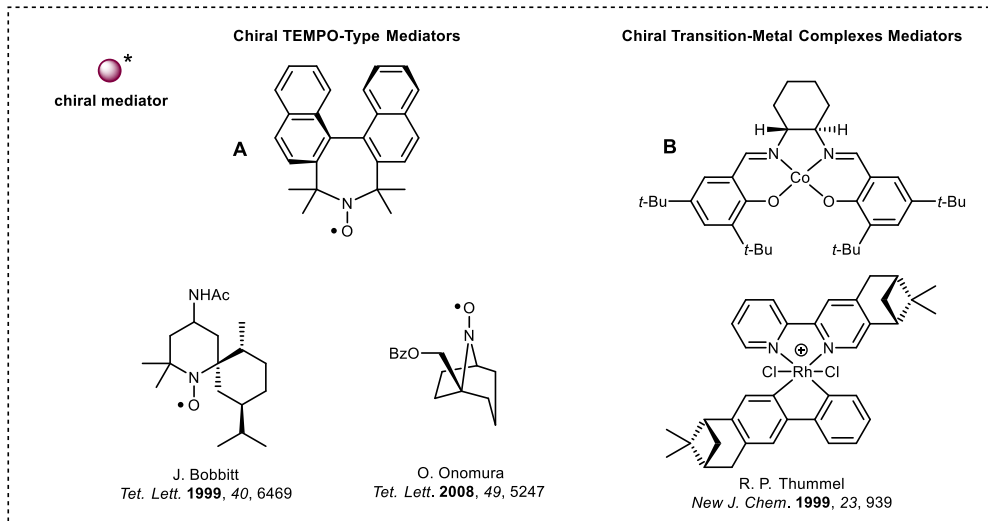
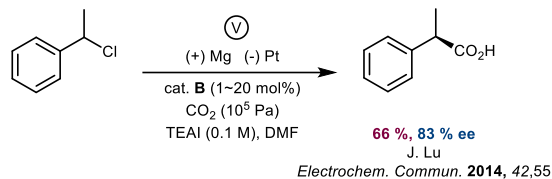
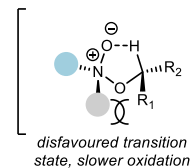
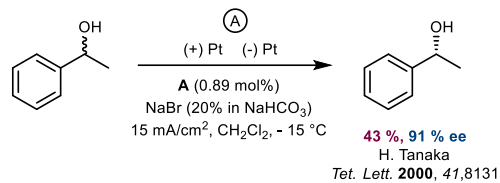

Asymmetric Electrochemical Catalysis

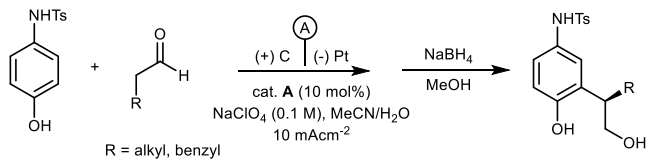

61-75 %, 81-96 % ee
 Jorgensen
ACIE, **2010**, 49, 129.

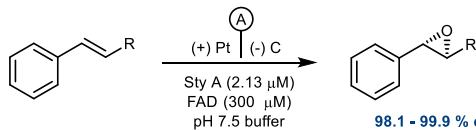

98.1 - 99.9 % ee
 A. Schmid
JACS, **2005**, 127, 6540

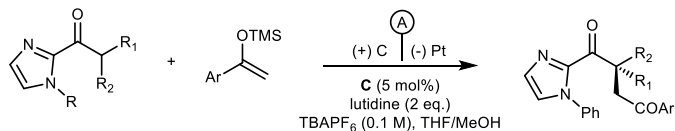

42 - 83 %, 96 % ee
 E. Meggers
Nat. Catal. **2019**, 2, 34

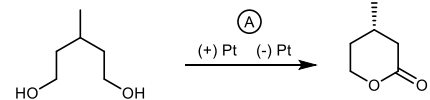
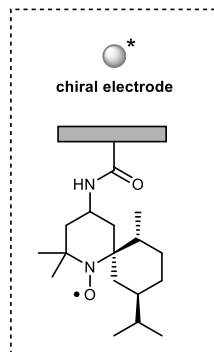
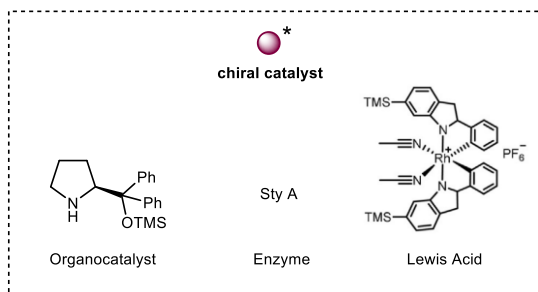
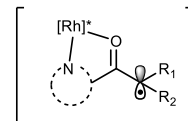

96 %, 98 % ee
 J. M. Bobbitt,
Chem. Commun. **2003**, 114

Photo-Electrochemistry



'Cross-pollination between toolboxes' 'The dawn of a new alliance'

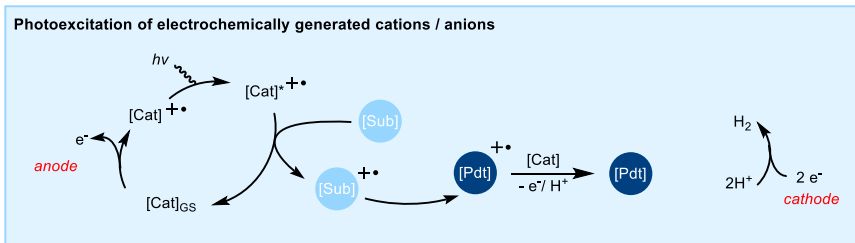

Electron exchange as the common point

- boarder redox window
- selectivity
- sacrificial oxidant/reductant free
- 'redox energy top-up'

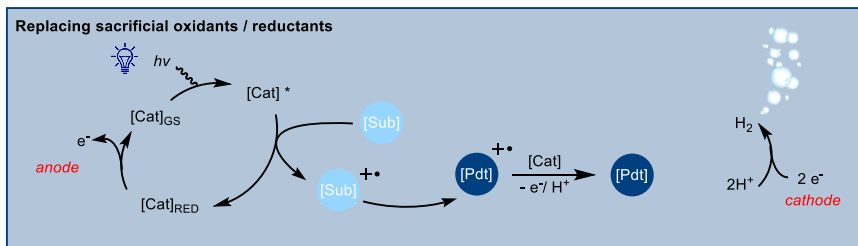

direct electrolysis (3.0 V)



electrophotocatalytic

Photo-Electrochemistry

'Cross-pollination between toolboxes' 'The dawn of a new alliance'

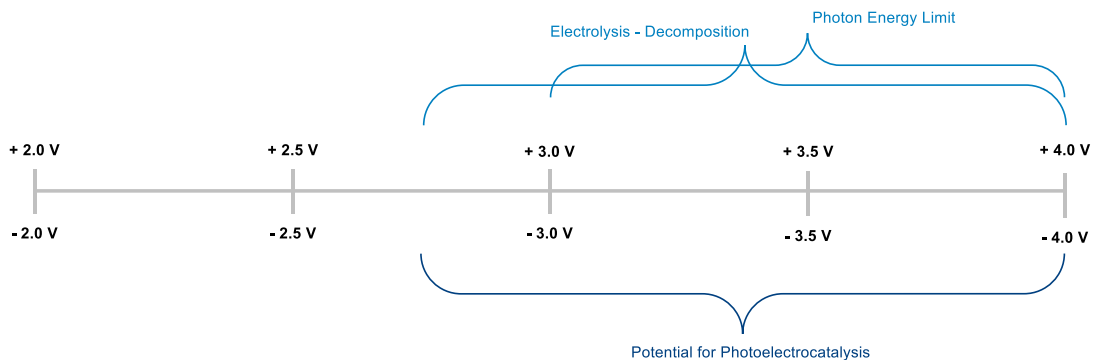

Photo-Electrochemistry

'Cross-pollination between toolboxes' 'The dawn of a new alliance'

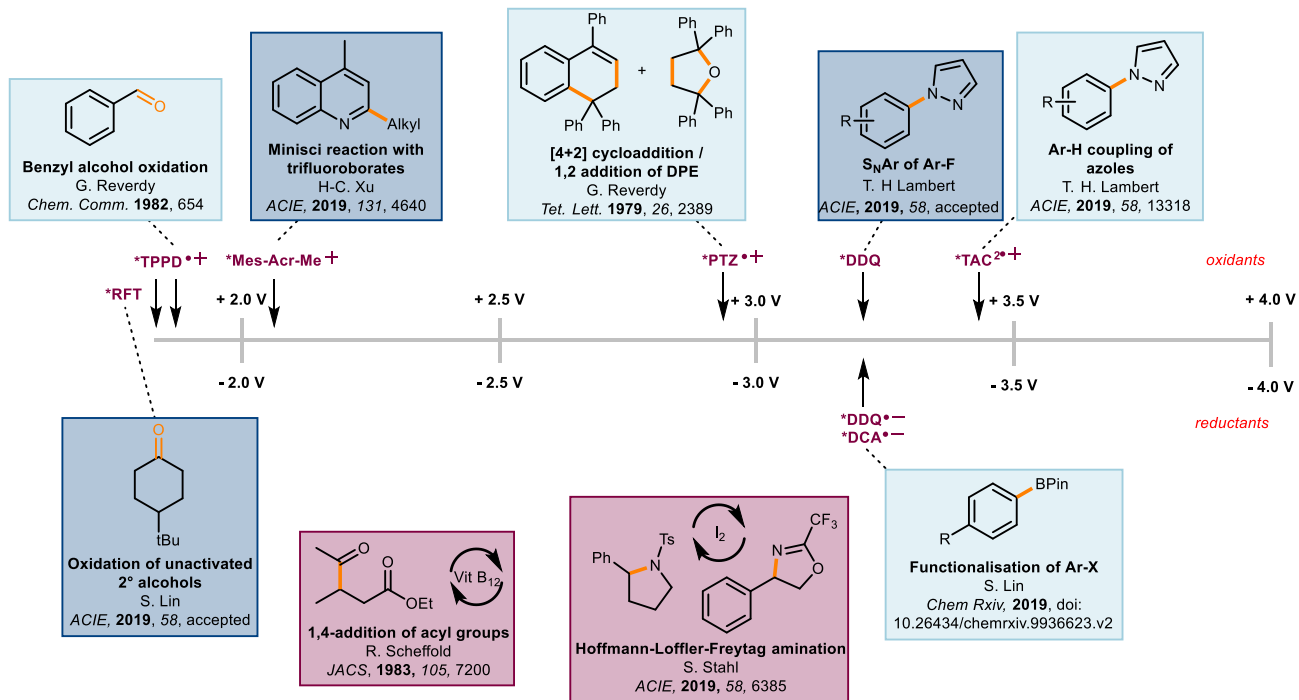
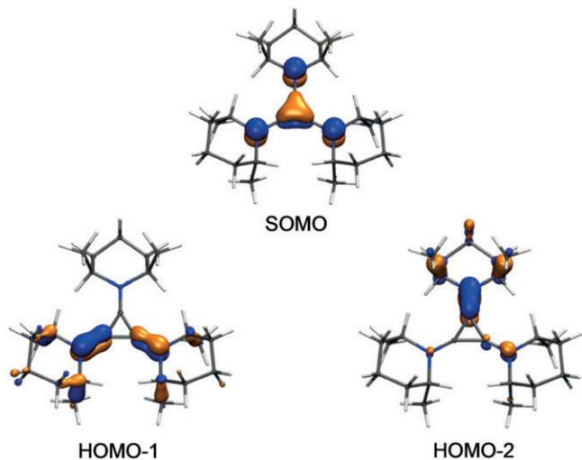
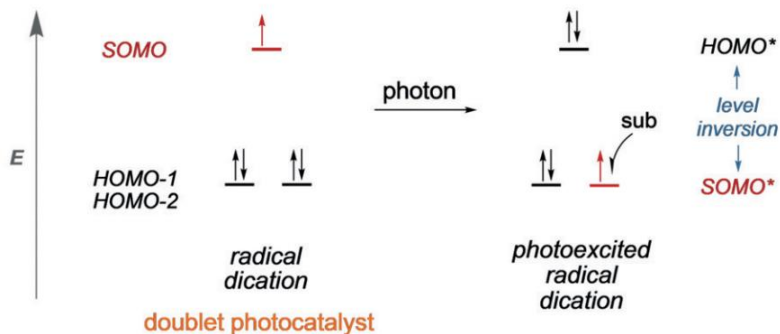
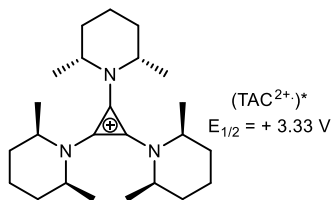
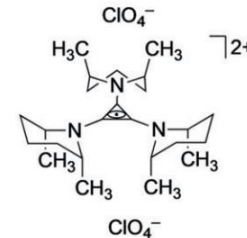
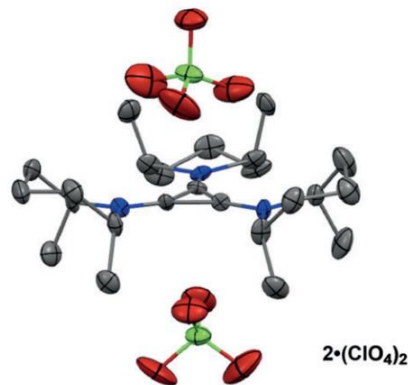

Photo-Electrochemistry: TAC²⁺*



TD-DFT



Crystal structure of TAC radical dication

- piperidine α-H orthogonal to TAC π-system protected from deprotonation / abstraction •

Photoelectrodes

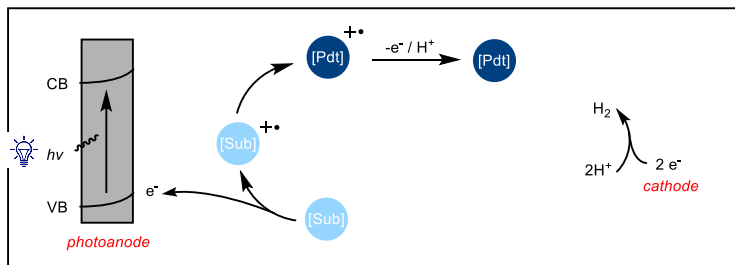

- One electrode is coated with a photoresponsive material • ‘visible light to offset high applied electrode potentials’

$\alpha\text{-Fe}_2\text{O}_3$
VB + 2.30 V

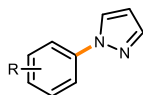

Ar-H coupling with azoles
X. Hu
Nat. Cat., **2019**, 2, 366.

BiVO_4
VB + 0.8 V

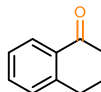

Oxidations of small organic compounds
J. Kasahara
Nat. Comm., **2017**, 8, 1.

$\text{BiVO}_4 / \text{WO}_3$

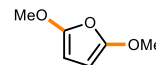

Oxidative dimethoxylation of furan
H. Tatano
Chem. Comm., **2017**, 53, 4378.

Summary and Conclusion

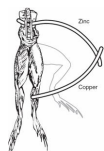

Introduction

- Organic Electrochemistry
- Key Milestones
- Underlying theory

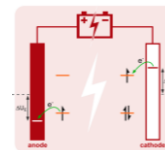

Practicalities & Applications

- Experimental Parameters
- Electrolysis Methods
- Applications
 - Industrial Processes
 - Natural Product Synthesis



Break

Methodology

- Anodic Oxidation
- Cathodic Reduction
- Paired Electrolysis
- Asymmetric Electrocatalysis
- Photo-electrochemistry



Summary & Conclusion



References

Introduction

- A Practical Beginner's Guide to Cyclic Voltammetry
J. Chem. Educ. **2018**, *95*, 197.
- Luigi Galvani and Alessandro Volta
Encyclopedia Britannica, **2019**
- Electrochemistry and Photoredox Catalysis: A Comparative Evaluation in Organic Synthesis.
Molecules **2019**, *24*, 2122.
- Experimental and Calculated Electrochemical Potentials of Common Organic Molecules...
Synlett, **2016**, *27*, 714
- Organic electrosynthesis: a promising green methodology in organic chemistry
Green Chem., **2010**, *12*, 2099.
- Fundamentals and Applications of Organic Electrochemistry: Synthesis, Materials and Device
T. Fuchigami et. al. *John Wiley & Sons*, Oxford, **2015**

Online Resources

- IKA, Electrosyn 2.0.
www.ika.com/electrosyn/Fundamentals.html
- Y. Kawamata, presentation
www.t.co/cLut8b7AZH
- Y. Kawamata, **2016**, presentation
www.baranlab.org/wp-content/uploads/2018/08/Group-Meeting-61210-ver4.pdf
- B. Rosen, **2014**, presentation
www.scripps.edu/baran/images/grpmtgpdf/Rosen_2014.pdf
- N. Ambhaikar, **2005**, presentation
www.scripps.edu/baran/images/grpmtgpdf/Ambhaikar_Dec_05.pdf

Industrial Applications

- Organic Electrosynthesis: From Laboratorial Practice to Industrial Applications.
Org. Process Res. Dev. **2017**, *21*, 1213.

Natural Products

- Dixiamycin B
J. Am. Chem. Soc. **2014**, *136*, 5571
- Hirsutene
J. Am. Chem. Soc. **1981**, *103*, 2744
- Quadrone
Tet. Lett. **1990**, *31*, 485
- Subglutinol A
J. Am. Chem. Soc. **2018**, *140*, 7462
- Erinacine
Org. Lett. **1999**, *1*, 1535
- (-)-Alliacol – A
J. Am. Chem. Soc. **2004**, *126*, 9106
- Ducane
Electrochimica Acta, **2009**, *54*, 5077
- Guanacastepenes
Org. Lett. **2005**, 3425
- Ceftibuten
Org. Process Res. Dev., **2002**, *6*, 178
- Kopsidine
J. Chem. Soc. Perkin. Trans. **2001**, *1*, 1594
- Penicimutanin
Chem. Sci., **2019**, DOI: 10.1039/c9sc05252f

Reviews

- Synthetic Organic Electrochemical Methods Since 2000.
Chem. Rev. **2017**, *117*, 13230
- Benefits of Unconventional Methods in the Total Synthesis of Natural Products.
ACS Omega, **2018**, *3*, 17326
- Electrifying Organic Synthesis.
Angew. Chem. Int. Ed. **2018**, *57*, 5594
- Use of Electrochemistry in the Synthesis of Heterocyclic Structures
Chem. Rev. **2018**, *118*, 4485
- Recent Advances in C–H Functionalization Using Electrochemical Transition Metal Catalysis
ACS Catal. **2018**, *8*, 7179
- Electrochemical Transition-Metal-Catalyzed C–H Bond Functionalization: Electricity as Clean Surrogates of Chemical Oxidants
ChemSusChem, **2019**, *12*, 115
- Chemistry with Electrochemically Generated N-Centered Radicals
Acc. Chem. Res. **2019**, *52*, 12, 3339
- Modern Strategies in Electroorganic Synthesis
Chem.Rev. **2008**, *108*, 2265

Assymmetric Electrochemistry

- Asymmetric Electrochemical Catalysis.
Chem. Eur. J. **2019**, *25*, 10033

Photoelectrochemistry

- Merging Photocatalysis with Electrochemistry
Angew. Chem. Int. Ed. **2019**, *58*, 17508
- Synthetic Photoelectrochemistry
Angew. Chem, Int. Ed. **2019**, doi: 10.1002/anie.201913767

Miscellaneous

- Synthetic Organic Electrochemistry: Calling All Engineers
Angew. Chem. Int. Ed. **2018**, *57*, 4149
- Use of Electroauxiliaries for Introducing N-Acyliminium Ions Into Peptides
J. Am. Chem. Soc., **2006**, *128*, 1376

Specific examples directly referenced in text.